

Grifco® Direct-Drive Cable Winch*



Let's grow together®

For Poultry Feeder and Drinker Applications

These direct-drive poultry winches have been specifically designed for the electric lifting of broiler feeder, drinker and perch lines in typical poultry houses. The winches have been independently tested and are supported by a one-year warranty.

Key Features

- Designed and tested to perform in corrosive environments.
- The high-quality motor and gear box are fitted to a rigid 0.24-inch (6-mm) steel frame.
- Manual override permits operation in the absence of power.
- Built-in mechanical limits result in perfect positioning every time.



56928

Product may differ slightly from image shown.

56928 Winch Specifications			
kW	1.1 kW	Phase	Single
Amps	7.1 A	IP Rating	IP55
Hp	1.5 Hp	Lifting Capacity	2,200 lbs (1000 kg)
Voltage	208-230 V	Travel	12.8 ft (3.9 m)

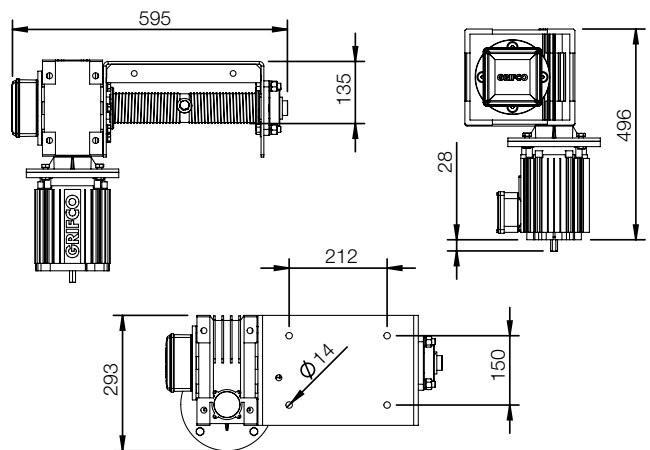

All above measurements in mm

*Grifco is not owned or licensed by CTB, Inc. and is the sole property of its owner.



Count on Chore-Time for experience, reliability, performance and confidence.



Use with CATALYST® Control for a complete package.



Let's grow together®

www.choretime.com

Chore-Time is a division of CTB, Inc.
A Berkshire Hathaway Company

Find your authorized independent distributor at choretime.com/distributor

Chore-Time
Milford, Indiana USA
info@choretime.com

Chore-Time Europe B.V.
Panningen, Netherlands
info@choretime.nl

Chore-Time Europe Sp. z o.o.
Strykowo, Poland
info@choretime.pl

Chore-Time Ede B.V.
Ede, Netherlands
info@choretime.nl