

Grifco® Direct-Drive Belt Winch*

For Poultry Drinker Applications

These direct-drive poultry winches have been specifically designed for the electric lifting of drinker lines in typical poultry houses. The winches have been independently tested and are supported by a one-year warranty.

Key Features

- Designed and tested to perform in corrosive environments.
- The high-quality motor and gear box are fitted to a strong, versatile belt.
- Manual override permits operation in the absence of power.
- Built-in mechanical limits result in perfect positioning every time.

56929 Winch Specifications

kW	1.1 kW	Phase	Single
Amps	7.1 A	IP Rating	IP55
Hp	1.5 Hp	Lifting Capacity	885 lbs (400 kg)
Voltage	208-230 V	Travel	12.8 ft (3.9 m)

*Grifco is not owned or licensed by CTB, Inc. and is the sole property of its owner.



Let's grow together®



56929 Product may differ slightly from image shown.

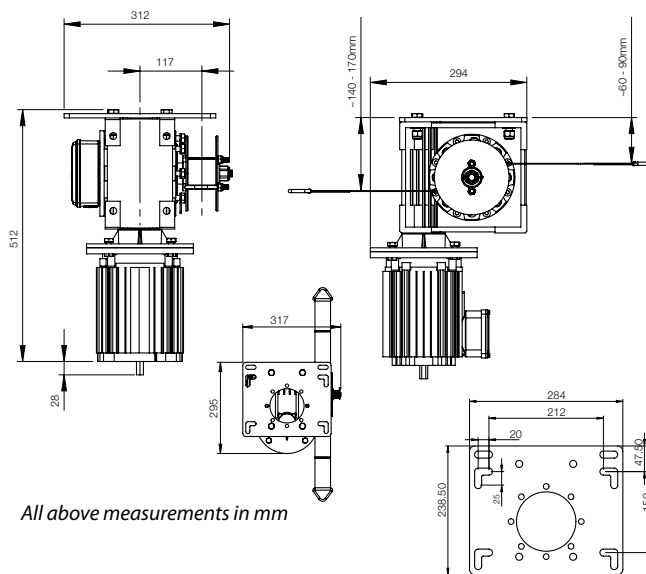

All above measurements in mm



Count on Chore-Time for experience, reliability, performance and confidence.



Use with CATALYST® Control for a complete package.



Let's grow together®

www.choretime.com

Chore-Time is a division of CTB, Inc.
A Berkshire Hathaway Company

Find your authorized independent distributor at choretime.com/distributor

Chore-Time
Milford, Indiana USA
info@choretime.com

Chore-Time Europe B.V.
Panningen, Netherlands
info@choretime.nl

Chore-Time Europe Sp. z o.o.
Strykowo, Poland
info@choretime.pl

Chore-Time Ede B.V.
Ede, Netherlands
info@choretime.nl