

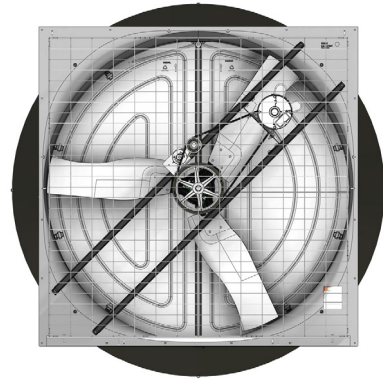

# 57" Belt Drive Endura® Fan Installation & Operator's Instruction Manual

**Thank You** The employees of CTB Inc. would like to thank you for your recent Chore-Time purchase. If a problem should arise, your Chore-Time distributor can supply the necessary information to help you.

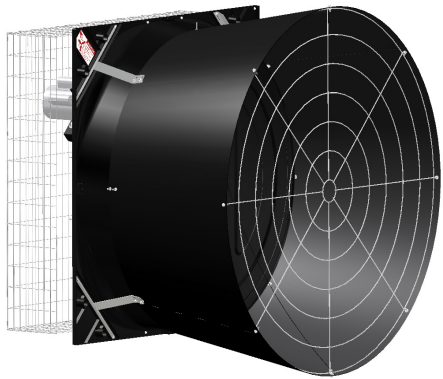

## Fan Part Numbers and Specifications

Fan Part No.	Bess Lab Test No.	Voltage	Phase	Hz	Nominal RPM	Amps	Starting Amps	Static Pressure at .10" w.c. [25 Pa]		Static Pressure at .15" w.c. [37.5 Pa]	
								CFM [cmh]	CFM/W [cmh/W]	CFM [cmh]	CFM/W [cmh/W]
53464-21 53464-21S	12615	230	1	60	542	6.9	36.0	30400 [51600]	20.4 [34.7]	28400 [48200]	18.1 [30.7]
53464-22 53464-22S	12614	230	1	60	543	5.4	27.5	27100 [46100]	23 [39.1]	25100 [42700]	20.1 [34.2]
53464-23	17224	230	1	60	538	4.0	27.5	21200 [36000]	24.6 [41.7]	18900 [32200]	20.8 [35.3]
53464-41 53464-41S	12616	200-230/400-460	3	60	534	4.8	43	30000 [51100]	20.9 [35.6]	27800 [47200]	18.1 [30.8]
53464-45	21134	230/460	3	60	594	6.0	43	33400 [56800]	18.6 [31.7]	31700 [53900]	16.9 [28.6]
53464-42 53464-42S	12619	200-230/400-460	3	60	539	4.1	43	26900 [45600]	23.3 [39.6]	24800 [42200]	20.4 [34.6]
53464-51 53464-51S	12617	200-230/380-415	3	50	527	5.2	45.0	29500 [50100]	20.8 [35.3]	27200 [46200]	18.1 [30.8]
53464-52 53464-52S	12618	200-230/380-415	3	50	534	4.7	45.0	26500 [45100]	22.9 [38.9]	24500 [41600]	20.1 [34.1]

Operating static pressure should be less than 0.15 inches water column [37.5 Pa].



**The Fan Inlet and exhaust must be kept clear of obstructions. Failure to keep the Fan airflow path clear of obstructions could cause loss of Fan performance and Fan damage.**

# Safety

## Warning



This product has inherent dangers, which can cause damage or loss to persons or equipment if the warnings in this manual are not adhered to. Please read and follow all instructions.

## Personnel Requirements



This product must only be used by persons adequately trained in the hazards, dangers, and risks of the equipment.

All users of this product must be trained in the following areas:

- Health and safety hazards relating to use of this machine throughout its entire life cycle
- Devices provided for safety of the operator
- Instructions for safe shutdown in case of emergency

The employer must assume the following responsibilities:

- To provide necessary personal protective equipment required
- To ensure normal maintenance operations are carried out
- To provide necessary repair parts in a timely manner



## General Requirements

Safety devices must remain in good working condition and may not be bypassed or rendered ineffective. The fan must not be operated with guards removed. All maintenance work must be done with electrical power isolated from the machine via proper device in accordance with local and national laws. The user must ensure that the environmental and electrical supply conditions in which the fan operates are within the limits specified in this manual or on product labels. Modification to this machine in any way are prohibited unless given written consent by CTB, Inc. Unauthorized modifications will render the warranty void and can lead to hazardous situations.



## Safety Devices

This machine has been designed to operate with fixed guards in order to protect users from physical hazards on both inlet and outlet sides of this fan. They were designed in accordance with national standards. They must not be altered. They must remain in their fixings at all times of operation. If damage or destruction should occur, exact replacements should be fitted immediately. **Reference the technical documentation section at the back of this manual** for more information.

At the time of installation, a proper device should be fitted in the direct vicinity of the fan to act as an emergency stop device. This device must be supplied by the installer. The device must be of a type to satisfy the emergency stop device requirements below.

EN-IEC 60204-1 Section 10.7.2:

- a push-button operated switch with a palm or mushroom head type

Section 10.7.3:

- actuators of emergency stop devices shall be colored RED.



## Residual Risks

Despite the level of caution taken and the incorporation of safeguards, some risks will remain. This product has the following hazards:

Hazard	Safeguard	Operator Requirement
Cutting or trapping	Fixed guards	Maintain all fixed guards in proper location and good condition
Ejection of parts		
Stability	Design Installation Instructions	Maintain product in good operating condition according to manual
Electrical shock	Warning Labels Installation Instructions	Maintain hazard decals in good readable condition Install and operate in accordance with instruction in manual
Noise	Design	Wear hearing protection if in vicinity of product for extended time periods
Transport and Handling	Instructions	Reference manual for precautions to take during transport or handling of this product

## Follow Safety Instructions

Carefully read all safety messages in this manual and on your equipment safety signs. Follow recommended precautions and safe operating practices.

Keep safety signs in good condition. Replace missing or damaged safety signs.



# Warranty

## LIMITED WARRANTY

Chore-Time Group, a division of CTB, Inc. ("Chore-Time") warrants new CHORE-TIME Endura® Fans manufactured by Chore-Time to be free from defects in material or workmanship under normal usage and conditions, for One (1) year from the date of installation by the original purchaser ("Warranty"). Chore-Time provides for an extension of the aforementioned Warranty period ("Extended Warranty Period") with respect to certain Product parts ("Component Part") as set forth in the table below. If such a defect is determined by Chore-Time to exist within the applicable period, Chore-Time will, at its option, (a) repair the Product or Component Part free of charge, F.O.B. the factory of manufacture or (b) replace the Product or Component Part free of charge, F.O.B. the factory of manufacture. This Warranty is not transferable, and applies only to the original purchaser of the Product.

Component Part	Extended Warranty Period
Endura® Fan Housing and Cones (Including Composite Shrouds, Composite Doors and HDPE Cone Panels)	Five (5) Years

## CONDITIONS AND LIMITATIONS

THIS WARRANTY CONSTITUTES CHORE-TIME'S ENTIRE AND SOLE WARRANTY AND CHORE-TIME EXPRESSLY DISCLAIMS ANY AND ALL OTHER WARRANTIES, INCLUDING, BUT NOT LIMITED TO, EXPRESS AND IMPLIED WARRANTIES, INCLUDING, WITHOUT LIMITATION, WARRANTIES AS TO MERCHANTABILITY OR FITNESS FOR PARTICULAR PURPOSES. CHORE-TIME shall not be liable for any direct, indirect, incidental, consequential or special damages which any purchaser may suffer or claim to suffer as a result of any defect in the Product. Consequential or Special Damages as used herein include, but are not limited to, lost or damaged products or goods, costs of transportation, lost sales, lost orders, lost income, increased overhead, labor and incidental costs, and operational inefficiencies. *Some jurisdictions prohibit limitations on implied warranties and/or the exclusion or limitation of such damages, so these limitations and exclusions may not apply to you. This warranty gives the original purchaser specific legal rights. You may also have other rights based upon your specific jurisdiction.*

Compliance with federal, state and local rules which apply to the location, installation and use of the Product are the responsibility of the original purchaser, and CHORE-TIME shall not be liable for any damages which may result from non-compliance with such rules.

The following circumstances shall render this Warranty void:

- Modifications made to the Product not specifically delineated in the Product manual.
- Product not installed and/or operated in accordance with the instructions published by the CHORE-TIME.
- All components of the Product are not original equipment supplied by CHORE-TIME.
- Product was not purchased from and/or installed by a CHORE-TIME authorized distributor or certified representative.
- Product experienced malfunction or failure resulting from misuse, abuse, mismanagement, negligence, alteration, accident, or lack of proper maintenance, or from lightning strikes, electrical power surges or interruption of electricity.
- Product experienced corrosion, material deterioration and/or equipment malfunction caused by or consistent with the application of chemicals, minerals, sediments or other foreign elements.
- Product was used for any purpose other than for the care of poultry and livestock.

The Warranty and Extended Warranty may only be modified in writing by an officer of CHORE-TIME. CHORE-TIME shall have no obligation or responsibility for any representations or warranties made by or on behalf of any distributor, dealer, agent or certified representative.

# Un-Assembled Parts Packages



(53843-XX)  
Component Package

Fan Blade Part No.  
(on Blade Spider)

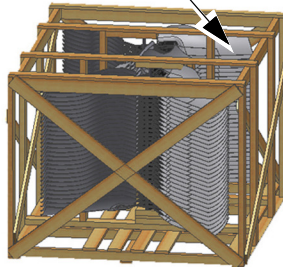

Fan Blade Package  
(53219-XX, 56494-XX, 54529-XX,  
56108-XX, or 57022-XX)



(53850-XX)  
Shroud and Door Package



Hardware Package  
(53788-AAXX, or -AAXXS)



(See Table Below)  
Motor Pallet

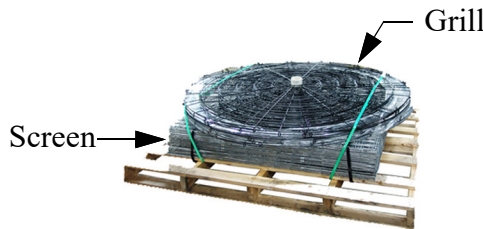

Grill: (53129)  
Screen: (48794)



Drive Assembly  
1 or 2 Drives per Box:  
(53753-1, -2, -1S, -2S)

### Un-Assembled 57" Belt Drive Endura® Fan Component Part Numbers

Fan Part No.	Drive Assembly	Motor	Hardware Pkg.	Fan Blade
53464-21U	53753-1	56708	53788-21XX	53219
53464-21SU	53753-1S	56708	53788-21XXS	54529
53464-22U	53753-1	56850	53788-22XX	56494
53464-22SU	53753-1S	56850	53788-22XXS	57022
53464-23U	53753-1	56850	53788-23U	56108
53464-41U	53753-1	56102	53788-41XX	53219
53464-41SU	53753-1S	56102	53788-41XXS	54529
53464-42U	53753-1	56102	53788-42XX	56494
53464-42SU	53753-1S	56102	53788-42XXS	57022
53464-45U	53753-5	56102	53788-45U	53219
53464-51U	53753-2	56102	53788-51XX	53219
53464-51SU	53753-2S	56102	53788-51XXS	54529
53464-52U	53753-2	56102	53788-52XX	56494
53464-52SU	53753-2S	56102	53788-52XXS	57022

XX= Number of Fans that can be built with components in Package.

# Assembled Fan Component Part Numbers

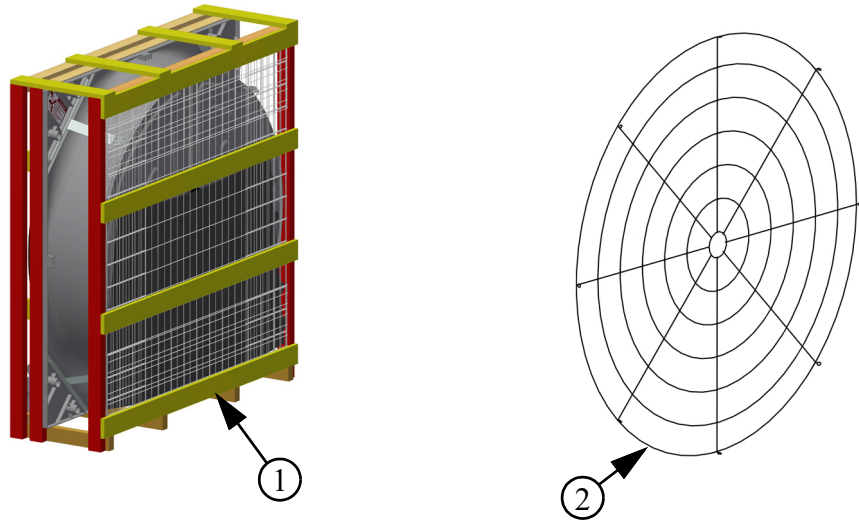

Assembled 57" Belt Drive Endura® Fan Component Part Numbers

Fan Assembly		53464-21	53464-21S	53464-22	53464-22S	53464-23	53464-41	53464-41S	53464-42	53464-42S	53464-45	53464-51	53464-51S
	Item	Component Part Numbers											
Fan Assembly	1	53464-21P	53464-21PS	53464-22P	53464-22PS	53464-23P	53464-41P	53464-41PS	53464-42P	53464-42PS	53464-45P	53464-51P	53464-51PS
Fan Grill	2	53129	53129	53129	53129	53129	53129	53129	53129	53129	53129	53129	53129

## Hardware Needed Per Fan (Un-Assembled)

<b>57" Belt Drive Endura® Fan Hardware Items Per Fan</b>			
<b>Items are Bulk packed in 53788-AAXX, or 53788-AAXXS (See previous page).</b>			
<b>Item</b>	<b>Qty.</b>	<b>Description</b>	<b>Part No.</b>
1	1	Bottom Pivot Plate	53036
2	1	Top Pivot Plate	53037
3	4	Door Hinge Pin	53038
4	1	1/4 x 1-1-8" Sq. Key (For Blade)	2419-2
5	40	5/16-18 x 1 SS Hx Hd Shoulder Bolt	54287
6	55	5/16-18 Hx. Serrated SS Flange Nut	46764
7	1	72" Fan Cone Cable	50618-5
8	1	5/16-18 x 3" Eye Bolt	30663
9	2	Ø1/2" x 11" Door Spring	49629
10	24	1/4-10 x 1-1/2" Lag Screw SS	41561
11	7	Open Eye Hook	1214
12	1	Screen Spring (4 pc. per package)	54480-4
13	6	Orifice Frame Bracket	53611
14	2	Cable Clamp	732
15	1	Fan Description Decal	39002-XXX
16	1	Anti-Seize Lubricant	56262
17	--	57" Endura® Fan Instruction Manual	MV2406

# Tools Needed and Supplies

3/8" socket, 1/2" socket or wrench, Side cutters, 1/4" nut driver, Motor power cord, Wire nuts / terminals, Optional screw hook installation tool (CTB part number 13150-1), Caulking, 5/32" allen wrench (un-assembled)

# New Installation Planning

Planning the layout of the spacing between Fans is very important. Spacing too close together will cause interference between the discharge Cones.

**!Important:** Provide Shelter over Cones in areas where snow or ice could cause damage. CTB Inc. Warranty **Does Not** cover damage from external sources.

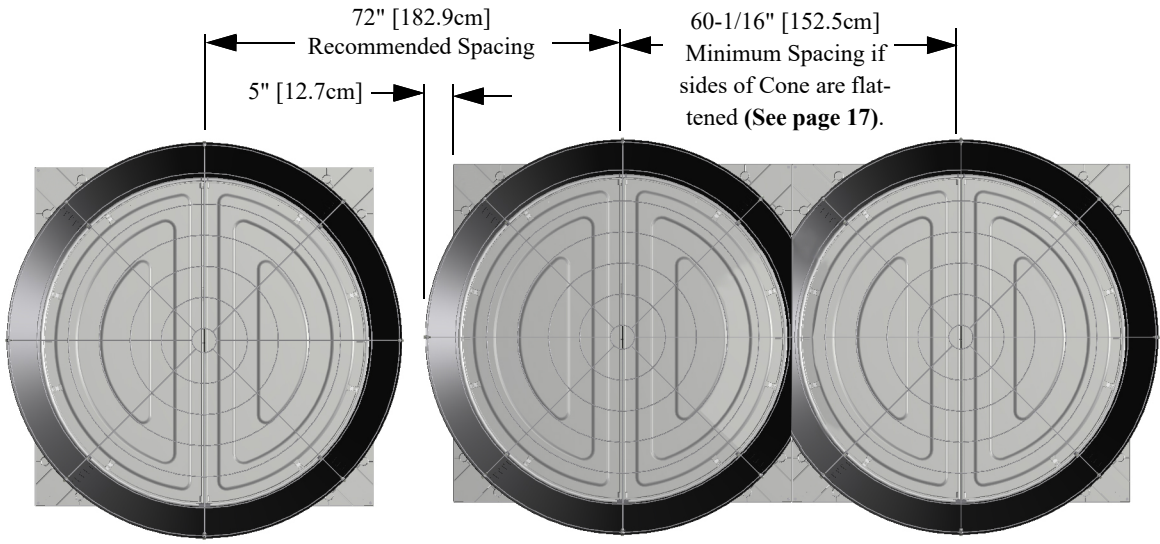
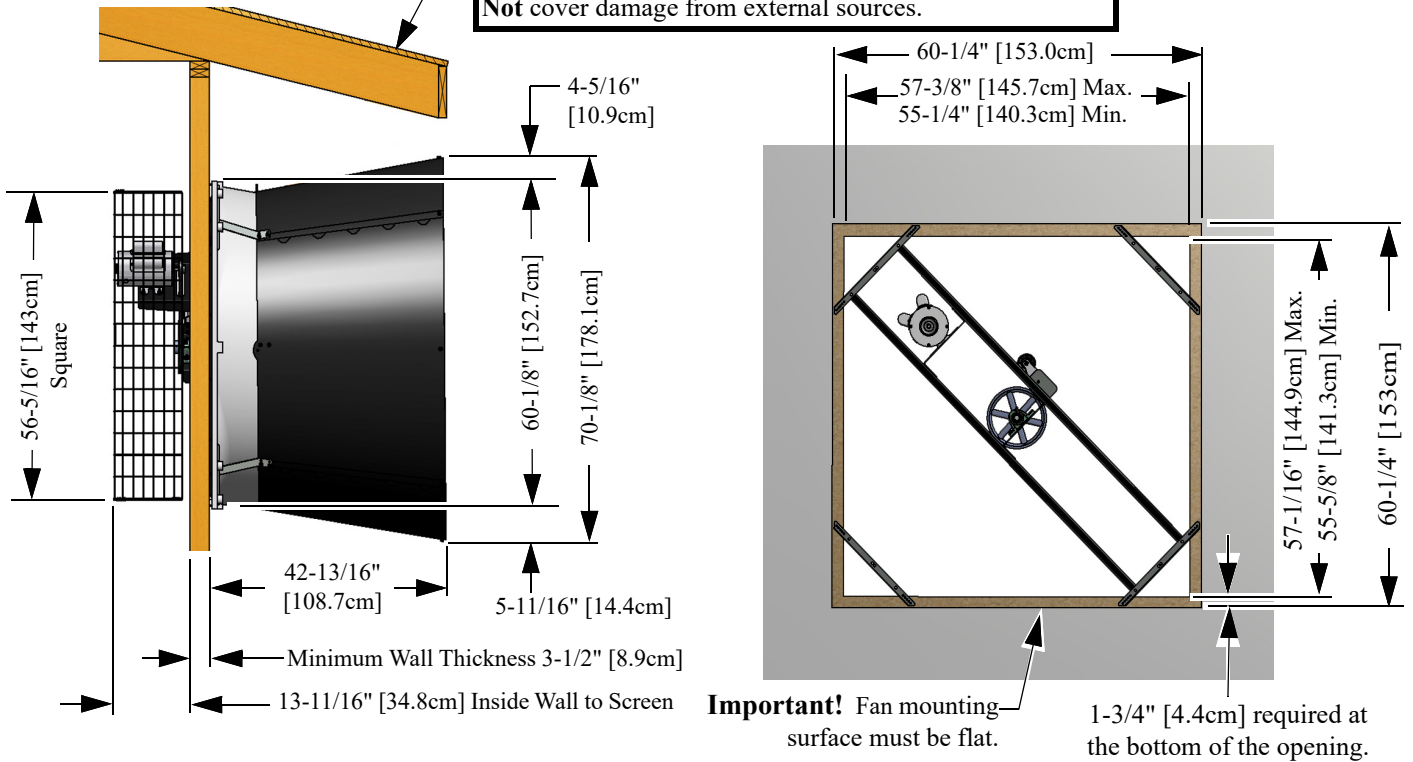



# Installation

## Inspecting the Shroud (For assembled versions skip to page 12)

Inspect the Shroud assembly for hardware as received.

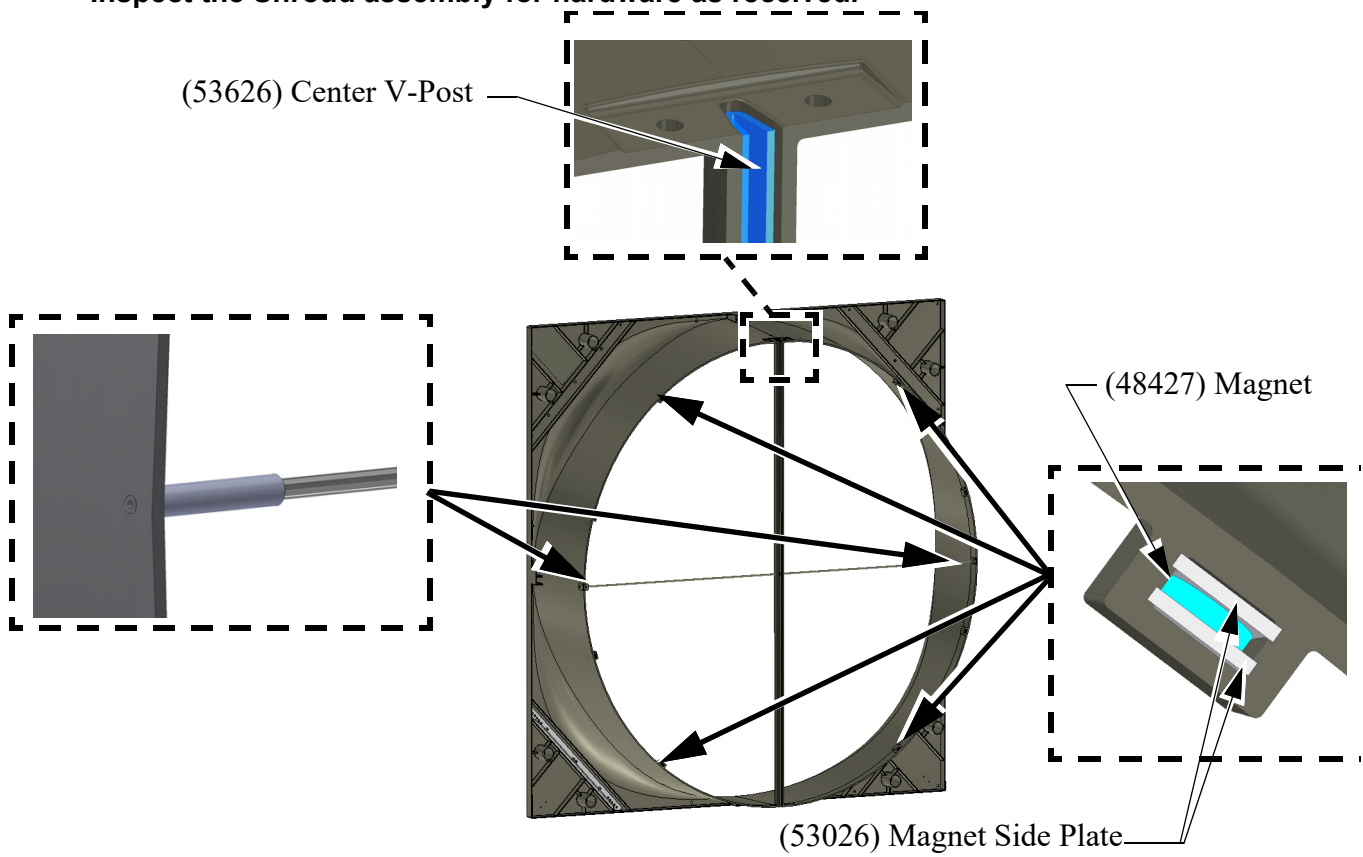

## Fan Shroud Assembly (Unassembled version)

Rest Fan Shroud on Saw Horses for ease of Assembly

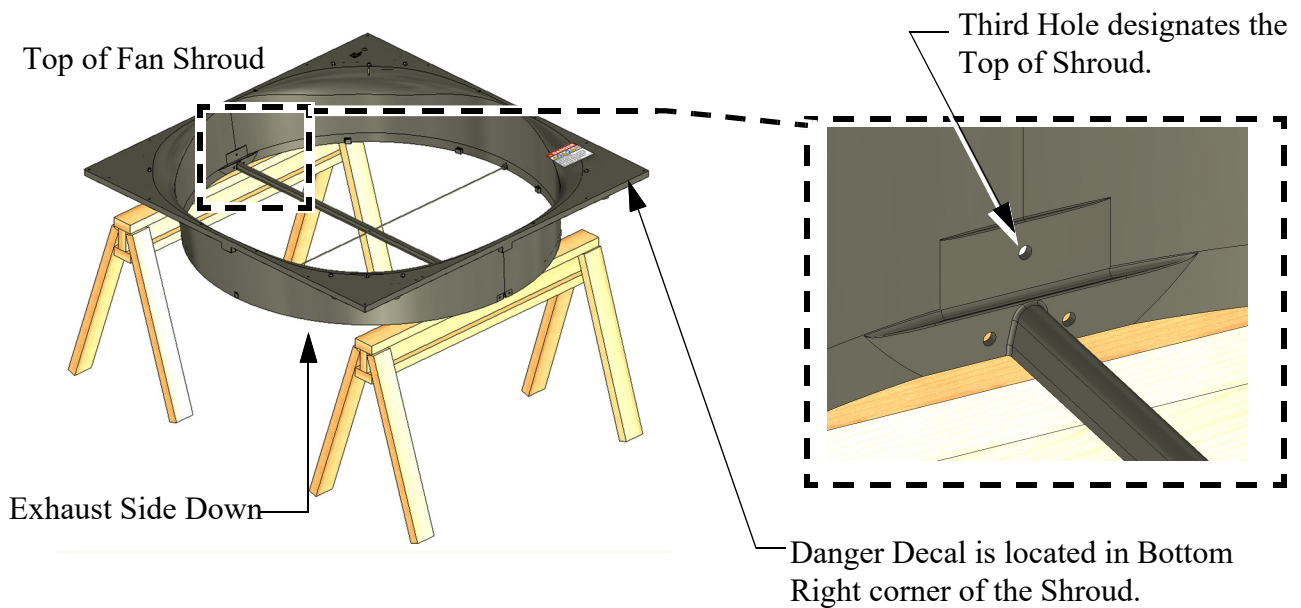

# Attaching Fan Posts

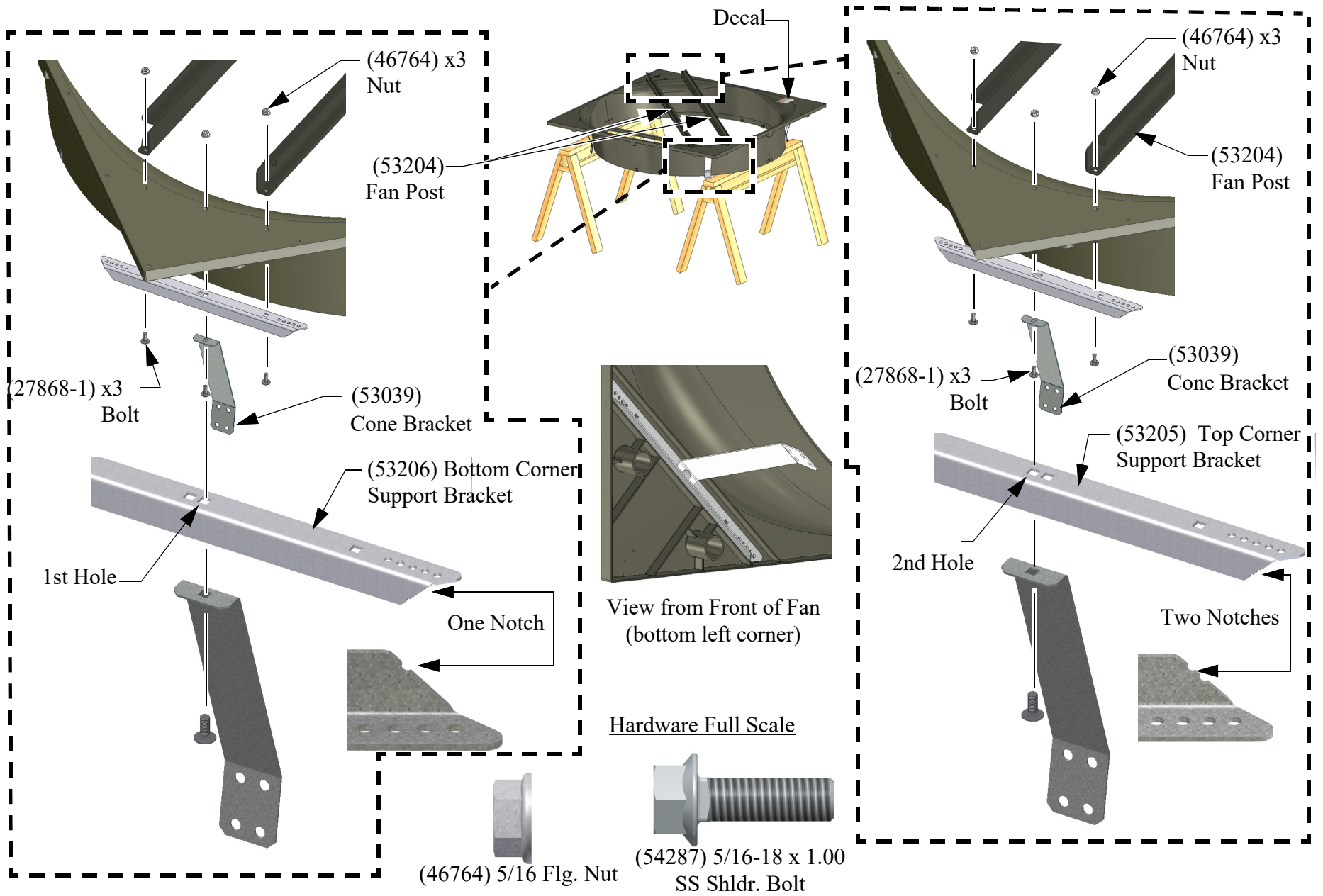

### Cone Brackets, Corner Brackets (Corners without Posts)

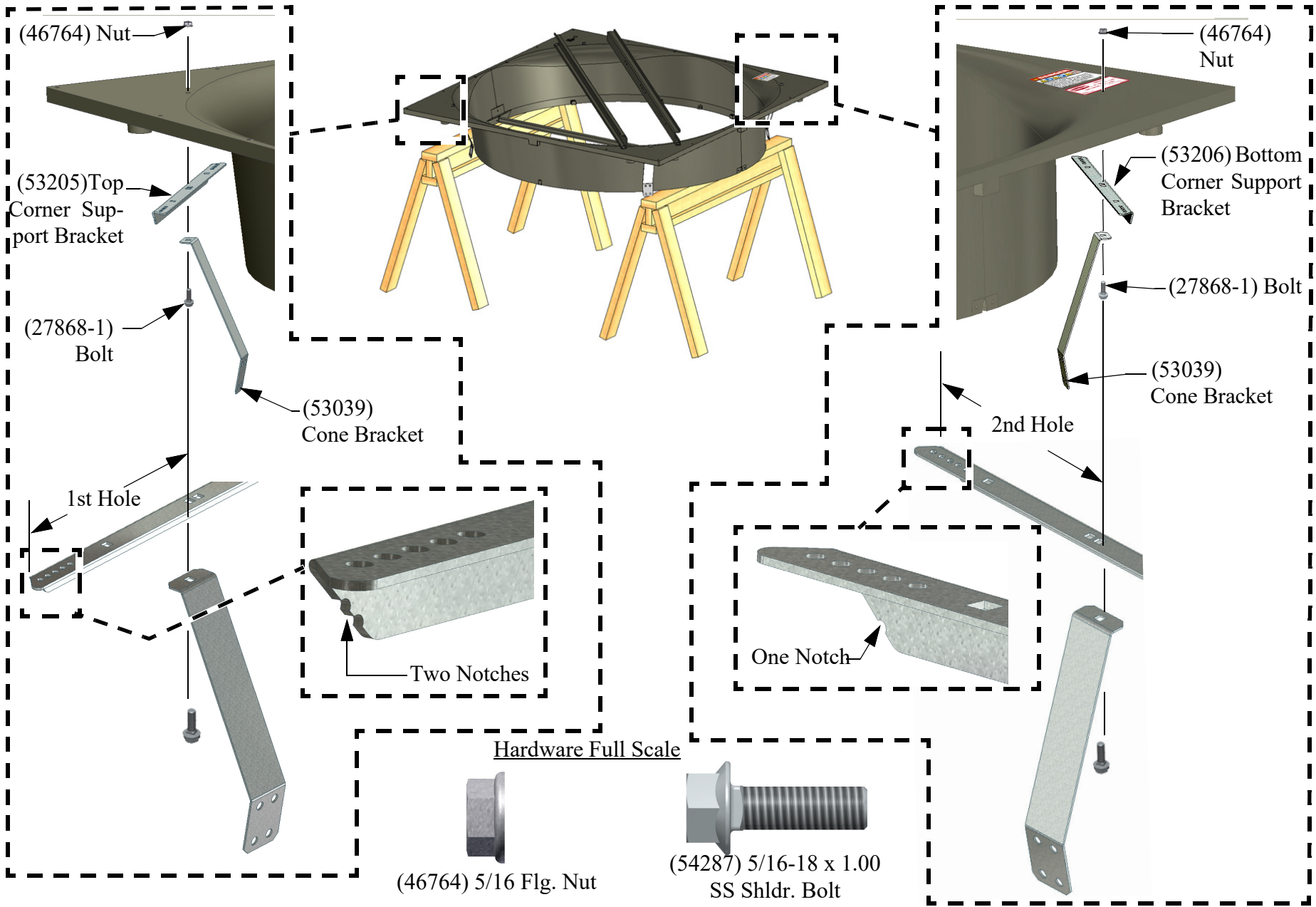

### Installing the Drive Assembly and Motor Mount



Apply a Fan Description Decal to the Shroud as shown. (Included in Parts Package)

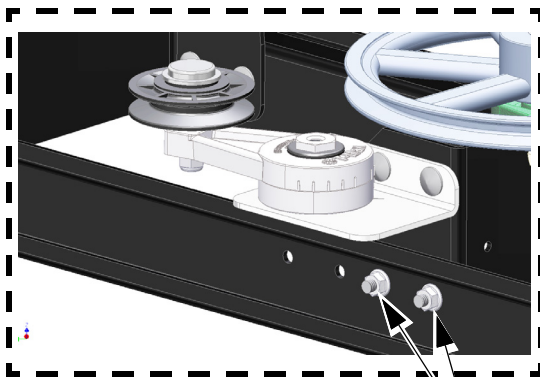
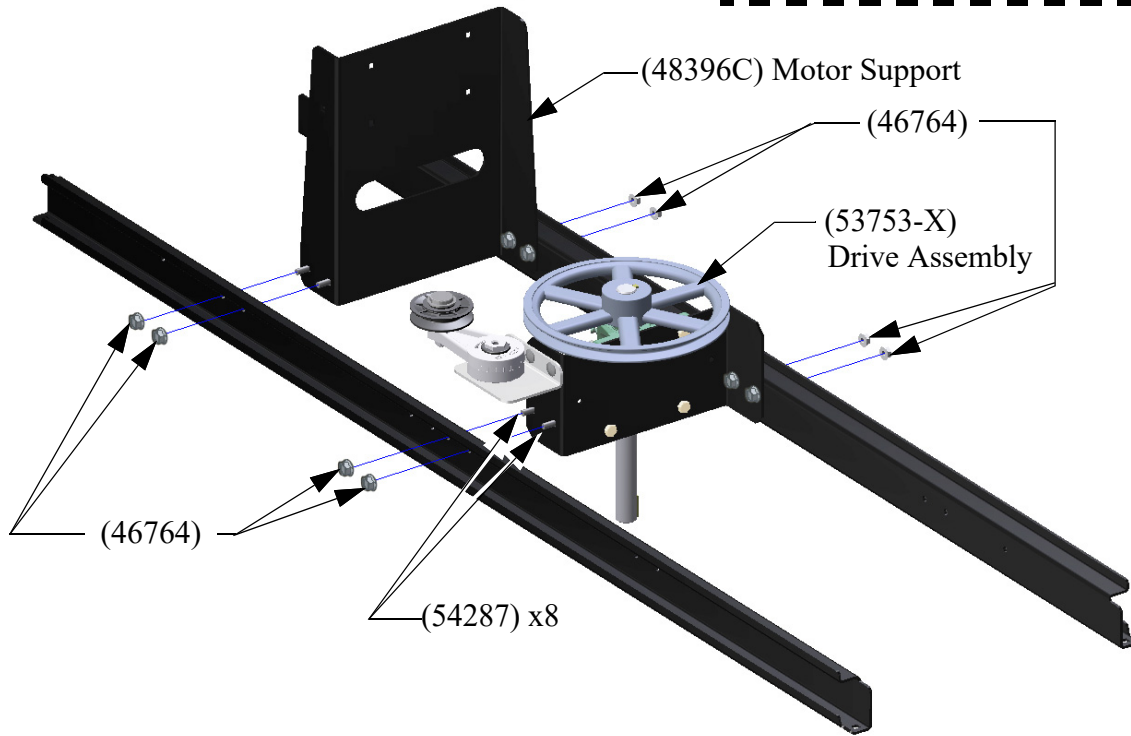

Use the Bottom Set of Holes in the Posts as shown.

Hardware Full Scale



(46764) 5/16 Flg. Nut

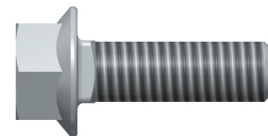

(54287) 5/16-18 x 1.00 SS Shldr. Bolt

### Top and Bottom Pivot Plates and Eyebolt, Door Stop Cable

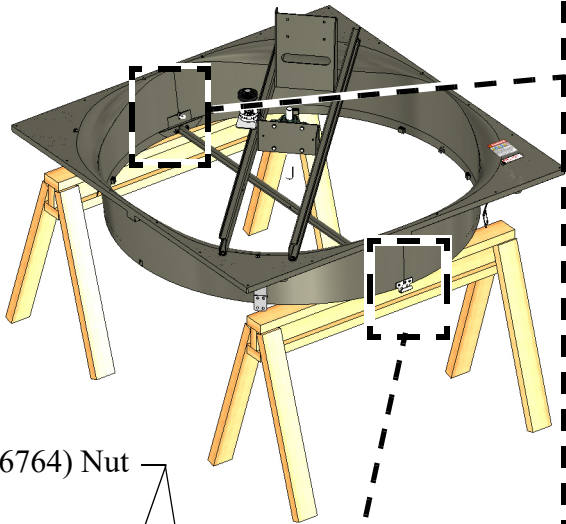

(46764) Nut

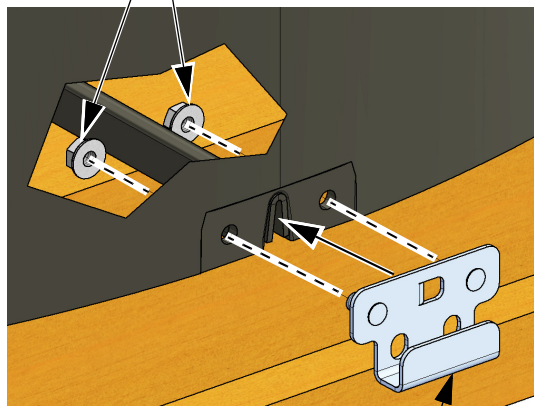

(53036) Bottom Pivot Plate

Pivot Plate Tab Centered in V-Post

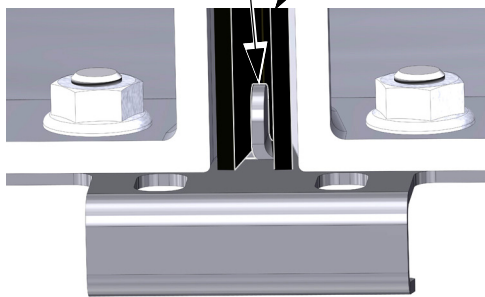

Hardware Full Scale



(46764) 5/16 Flg. Nut

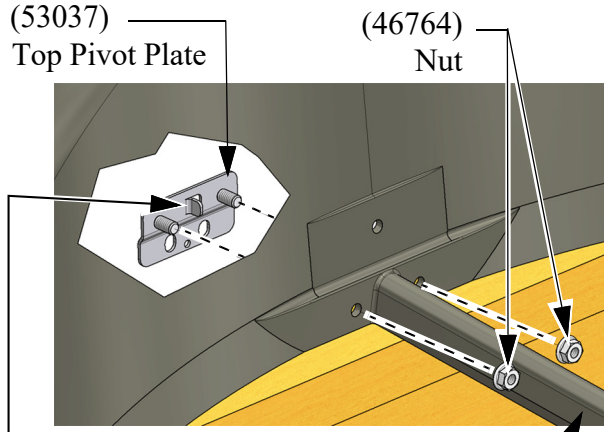

(53037) Top Pivot Plate

(46764) Nut

V-Post

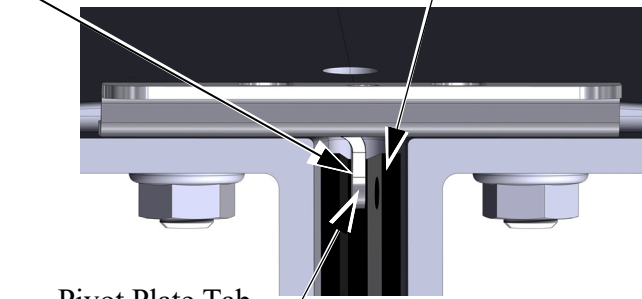

Pivot Plate Tab Centered in V-Post

(3066) Eyebolt

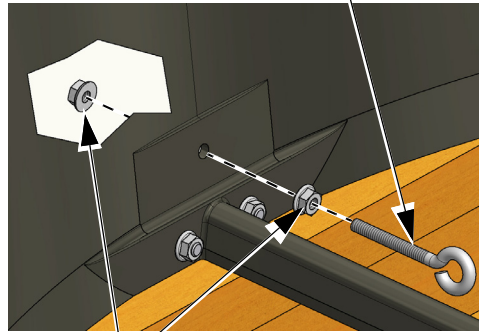

(46764) Nut

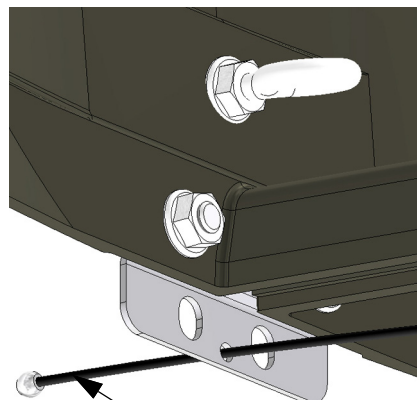
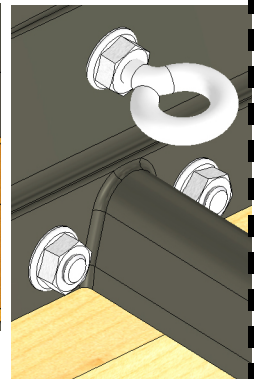

Insert (50618-5) Door Stop Cable Assembly into Top Pivot Plate

### Bottom Shelf Installation

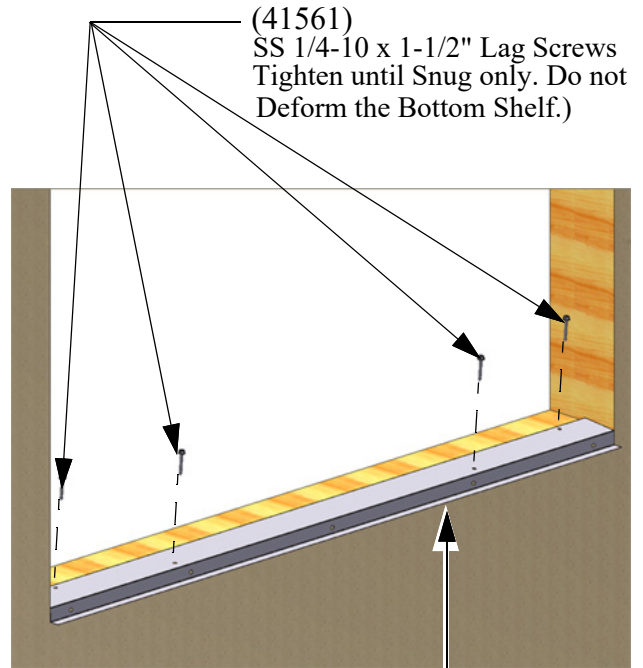
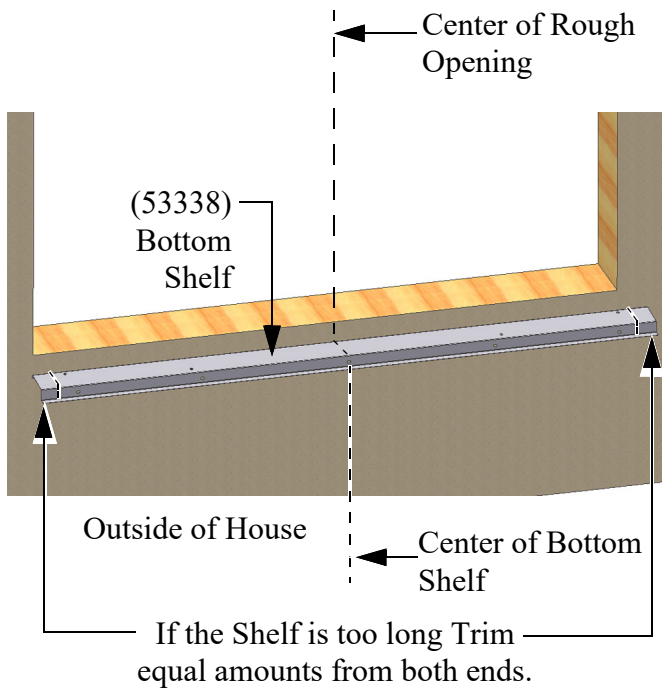

This Flange must not be bowed after installation!



(41561) 1/4 x 1-1/2 Lag Screw

### Attaching the Fan to the Wall

Eyebolt indicates the **Top** of the Fan.

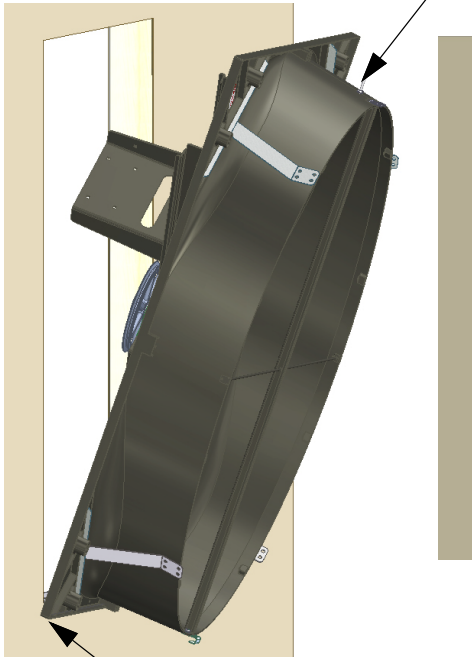

Set Fan Shroud on the Bottom Shelf.

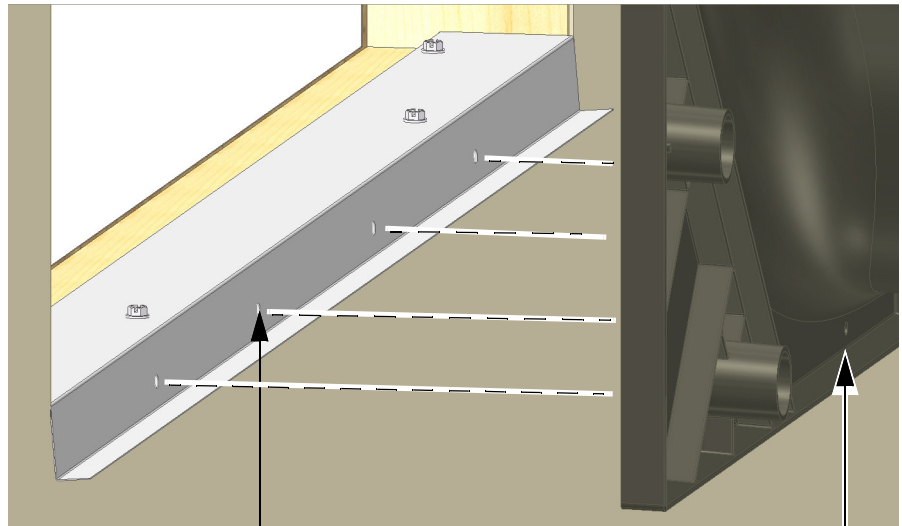

Line up the four Holes in the Shroud with the Holes in the Bottom Shelf.

It is important when attaching the Fan to the Wall to keep edges of Shroud straight.

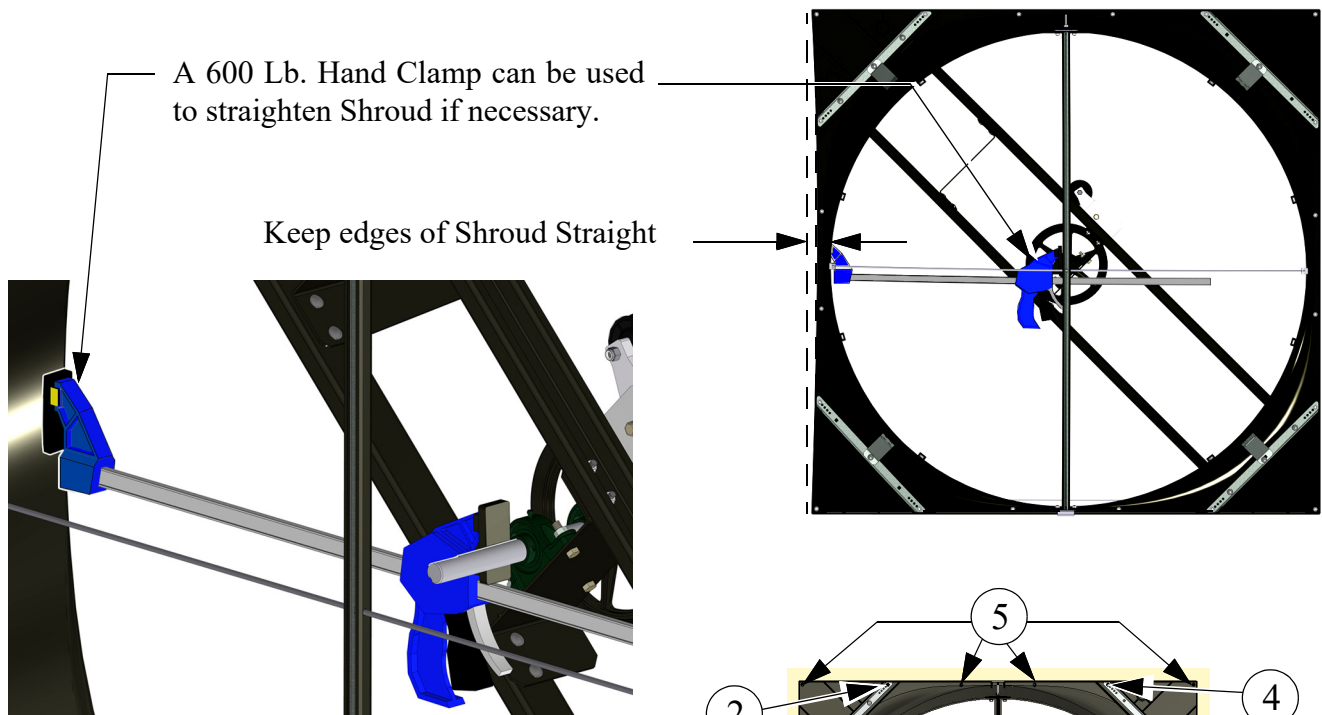

Pre-drill holes to 3/16" [4.8 mm] to avoid splitting lumber. If holes do not line up with the lumber it may be necessary to put Screws through Shroud. **Important! Attach the Fan to the Wall with 1/4 x 1-1/2" Lag Screws (41561) in the specific order shown. Attach with a total of 20 Lag Screws.**

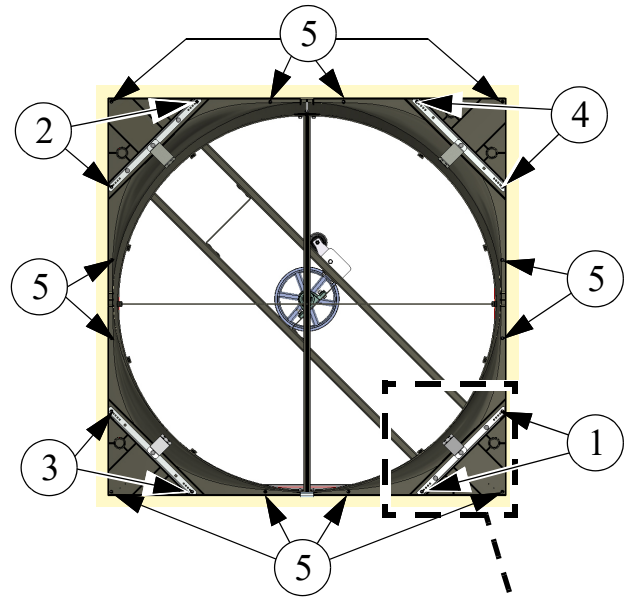

Use the Hole in the Corner Bracket that is centered with Lumber to avoid splitting.



(41561) 1/4 x 1-1/2 Lag Screw

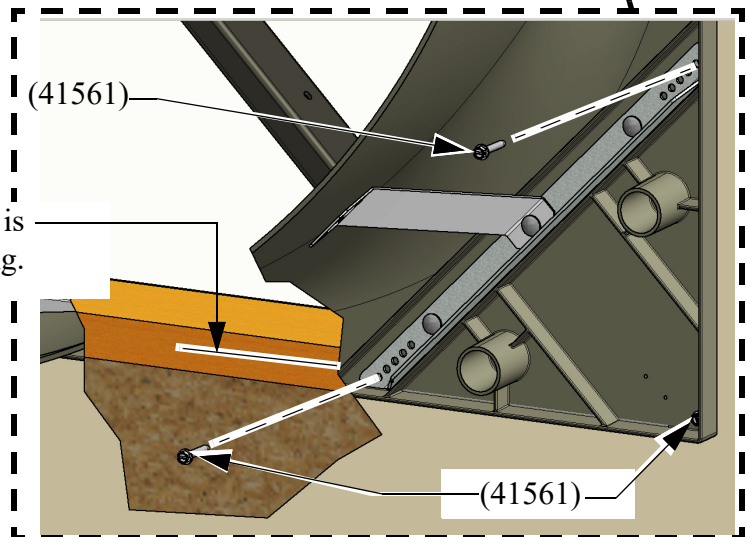

### Cone Assembly

Assemble Cone Panels as shown below.

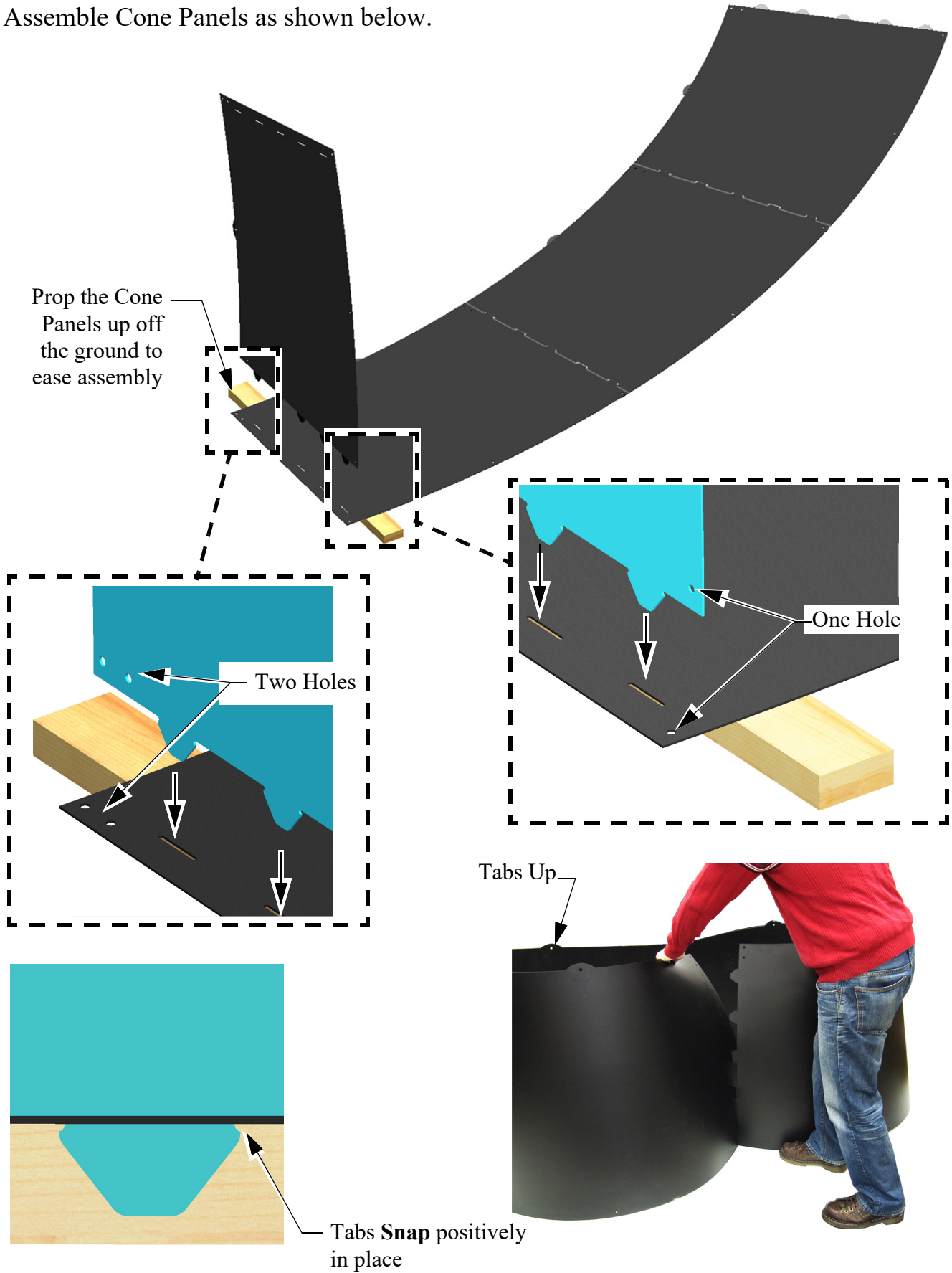



### Installing the Orifice Frame

Rounded Tab on the Cone

**Important!** Line up the Seam in the Orifice Frame with one of the rounded Tabs on the Cone.

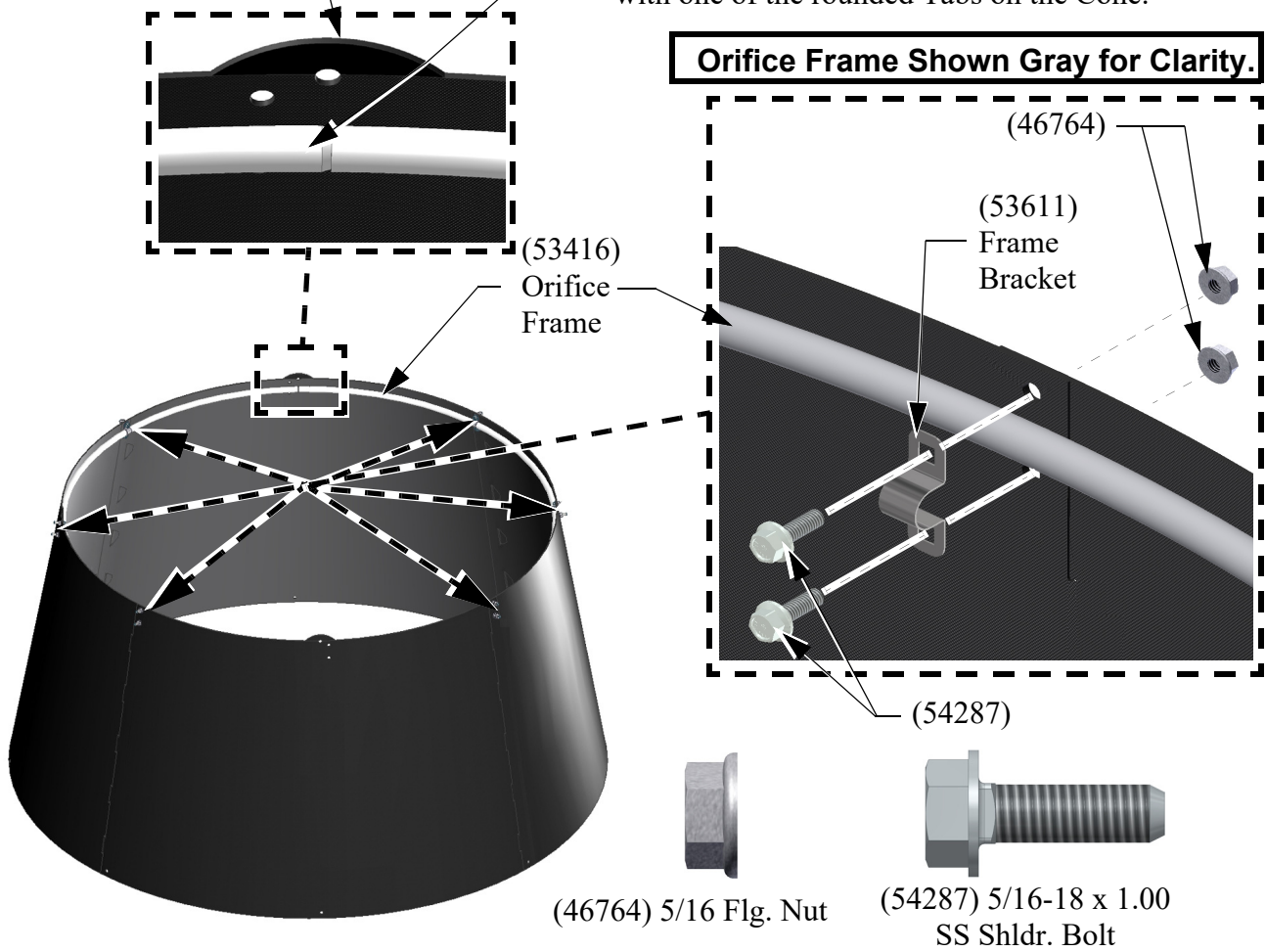

### Cone Installation

Hang the Cone on the Eye-Bolt extruding from the top of the Shroud using the hole in the Cone as shown.

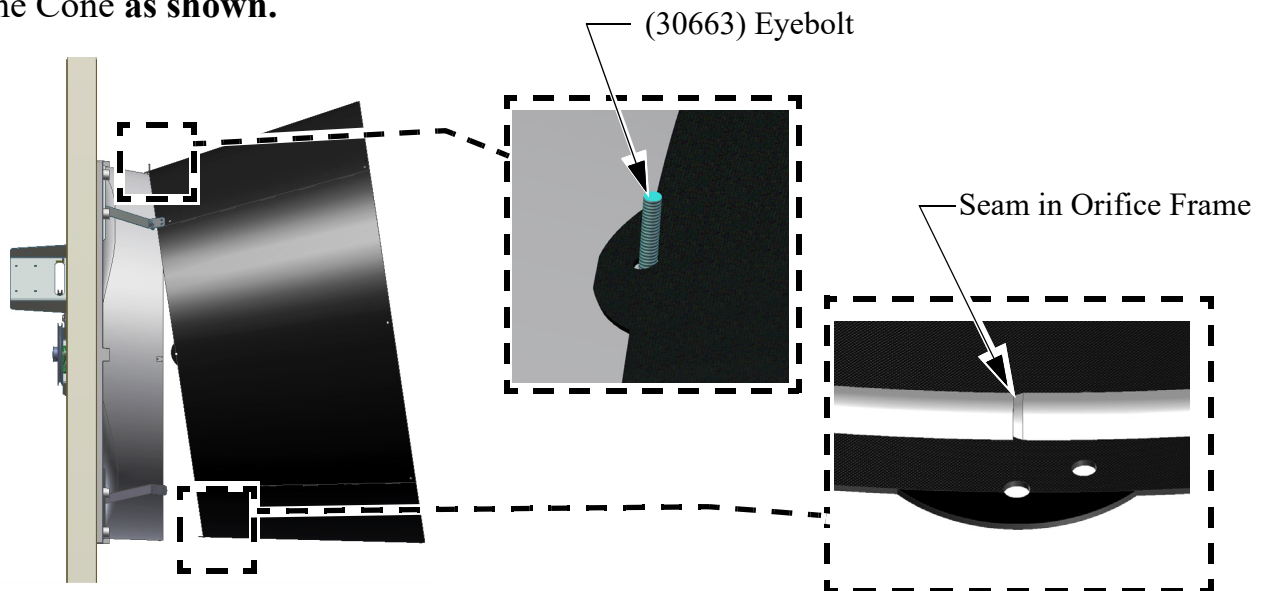

Attach the cone to the Shroud as shown below.

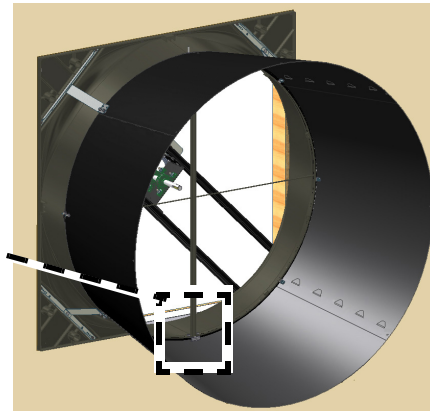
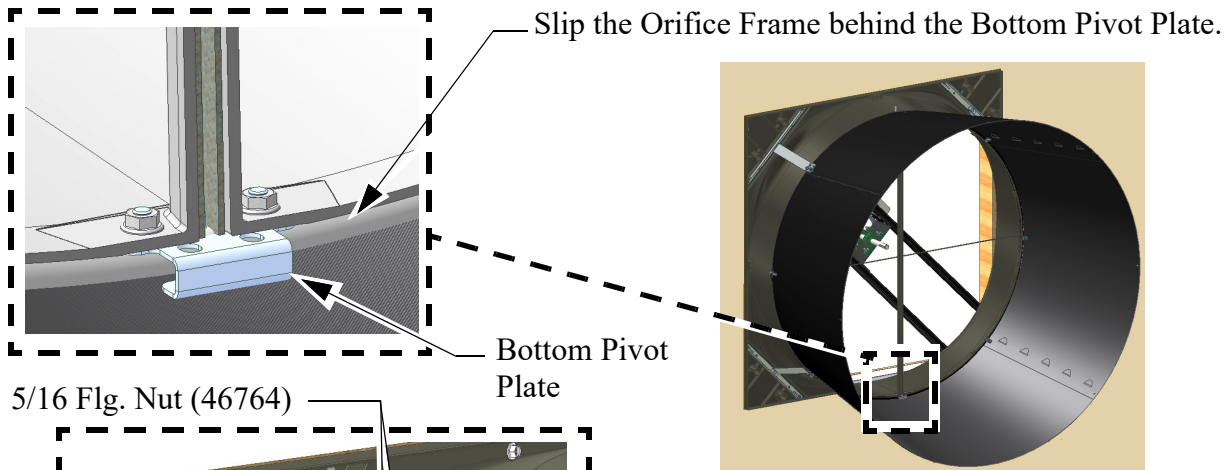

If necessary, slip a thin piece of metal between the Shroud and Cone and work it around the Cone to get it on.

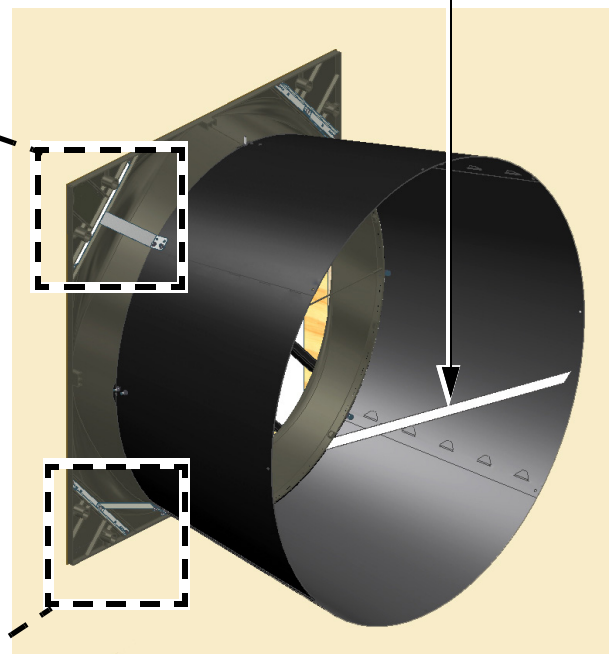

Use the Bolts in the Cone to attach the Cone to the Cone Brackets. Use the Bottom set of holes in the Cone Brackets.

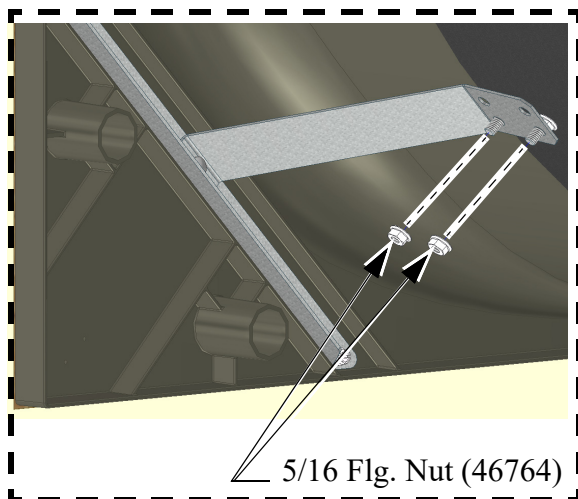

(46764) 5/16 Flg. Nut

### Door Assembly and Installation

Insert Door Pins in both Doors as shown.  
Push Pins in until they bottom out.

Doors are Left and Right specific.

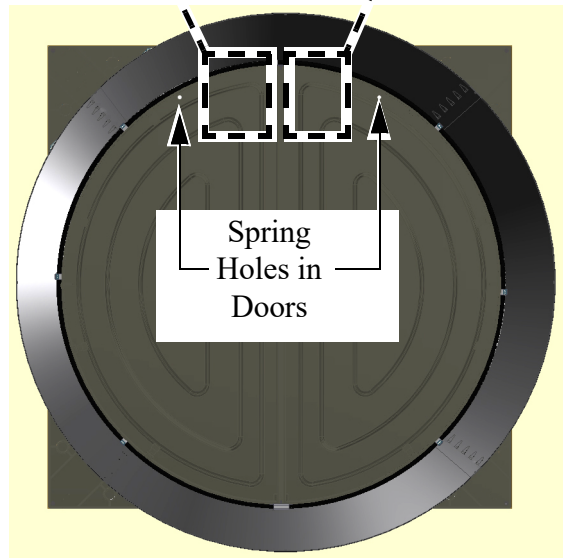
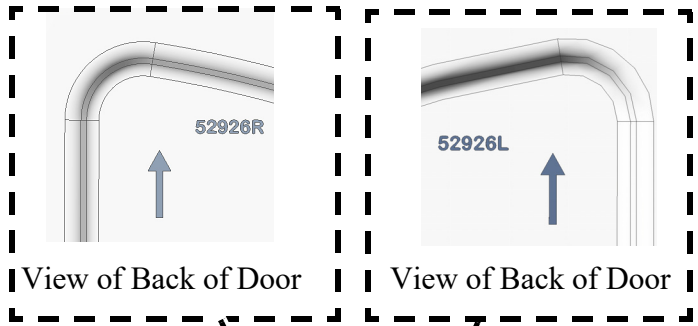
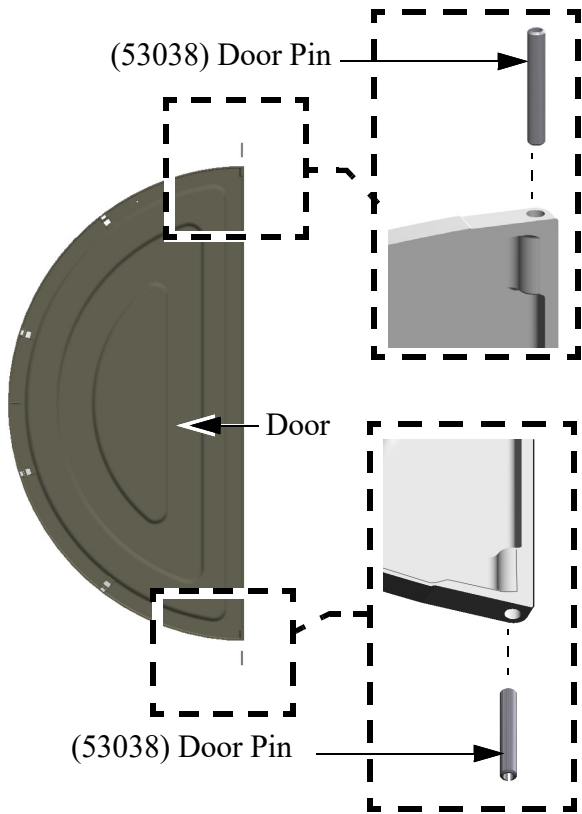

Insert Door Pins into Bottom Pivot Plate.

Grab the Door in the Center, Bow the Door outward, and insert the Top Door Pin into the Top Pivot Bracket as shown. **Do not Overbow the Doors!**

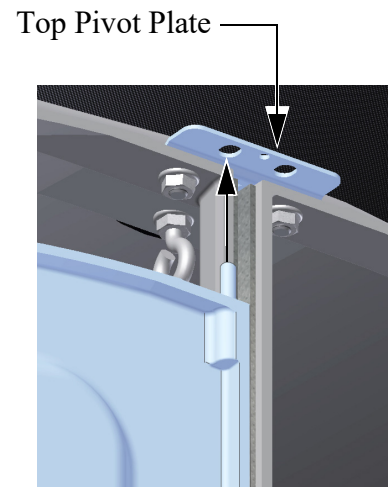
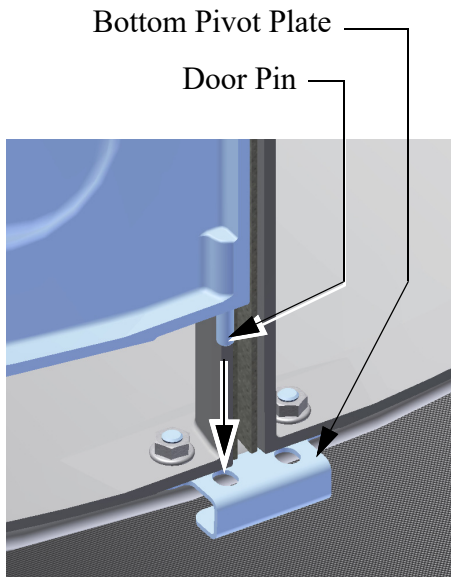

### Grill Installation

Install the Fan Cone Grill (as shown). Attach the end of the Door Stop Cable to the bottom Grill Leg as shown.

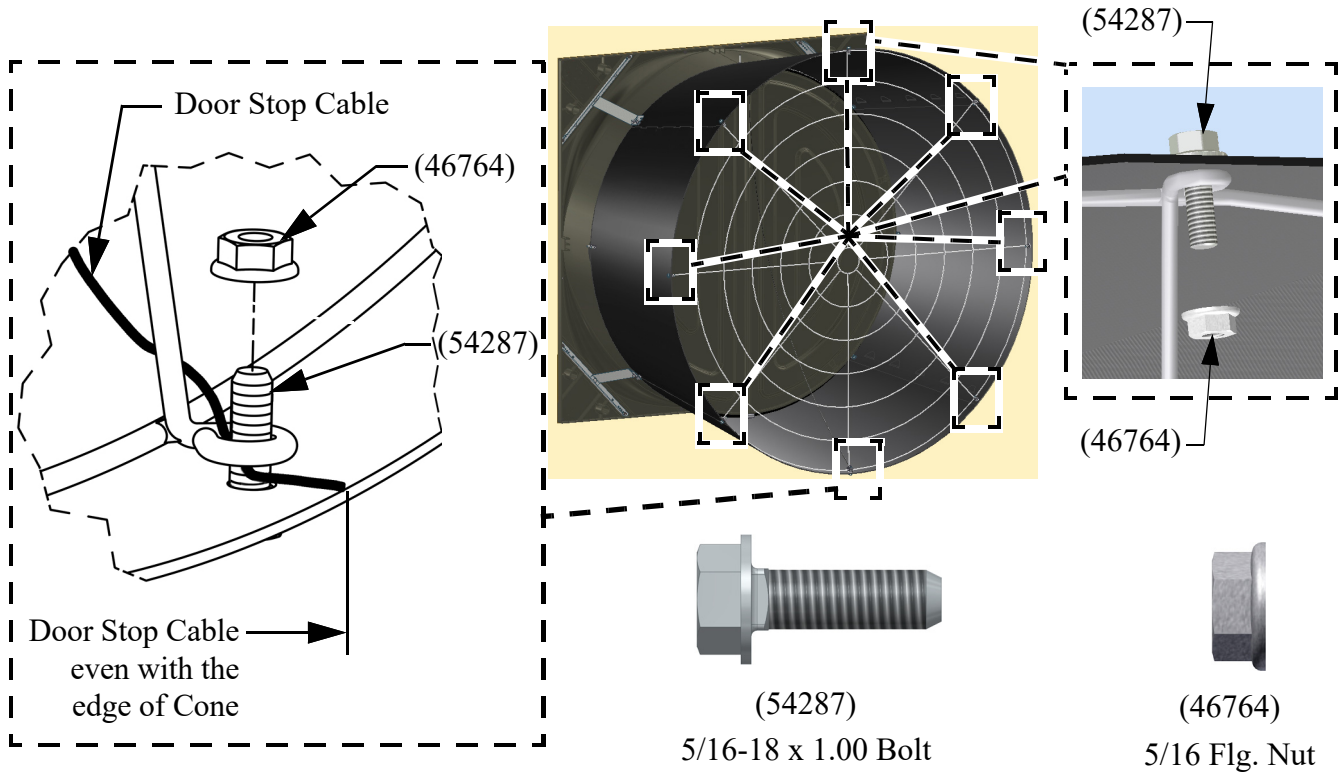

If it is desired to Mount Fans at the minimum spacing cutting the Grills is required as shown.

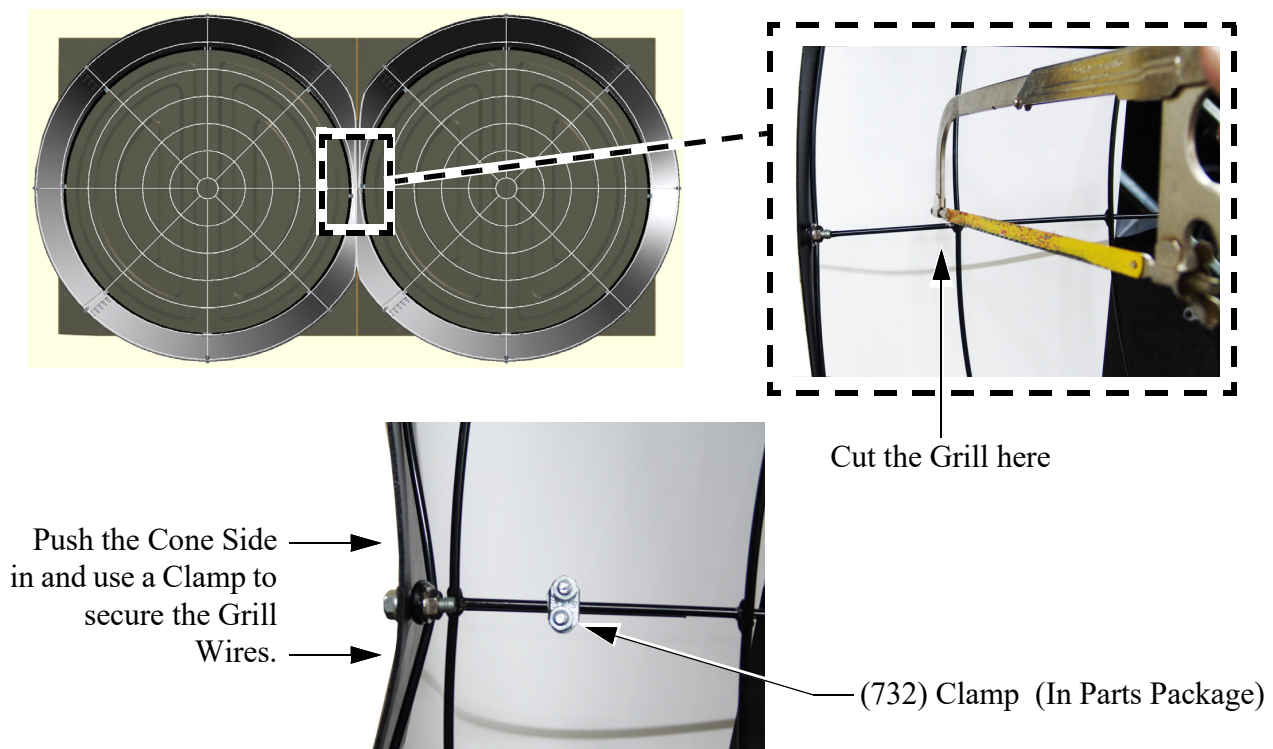

## Rotate Motor Support (Assembled Fans)

Rotate the Motor Support Bracket into the upright position by removing the **upper** Bolt and Nut, and loosening the **lower** Bolt and Nut.

Attach the Motor Support Bracket to the Posts with 5/16 Bolts (54287) and 5/16 Flange Nuts (46764).

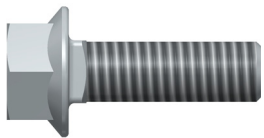
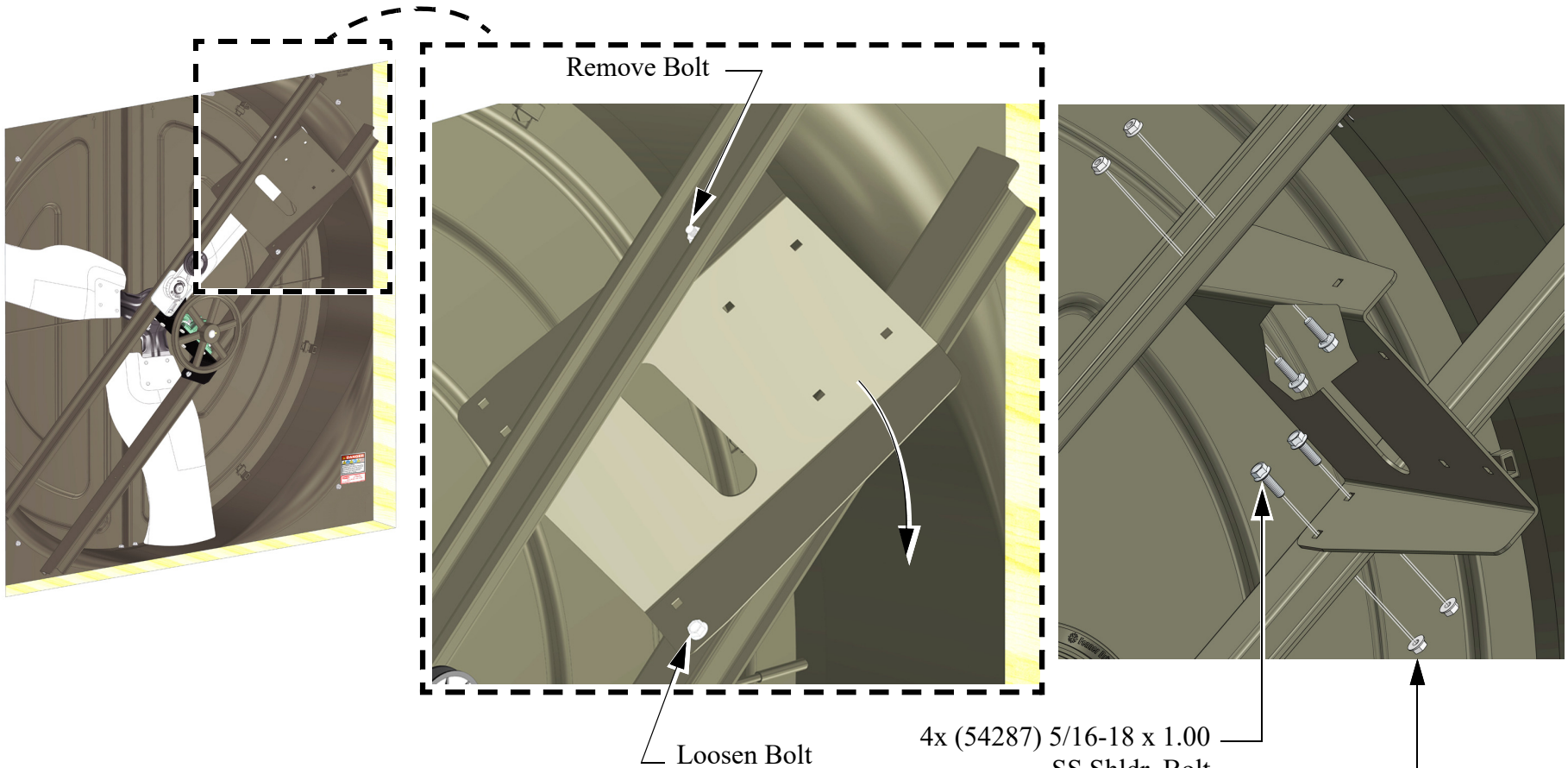

(54287)

5/16-18 x 1.00 SS Shldr. Bolt



(46764)

5/16 Flg. Nut

4x (54287) 5/16-18 x 1.00  
SS Shldr. Bolt

4x (46764) 5/16 Flg. Nut

### Motor Installation

Attach Motor to Z-Bracket.

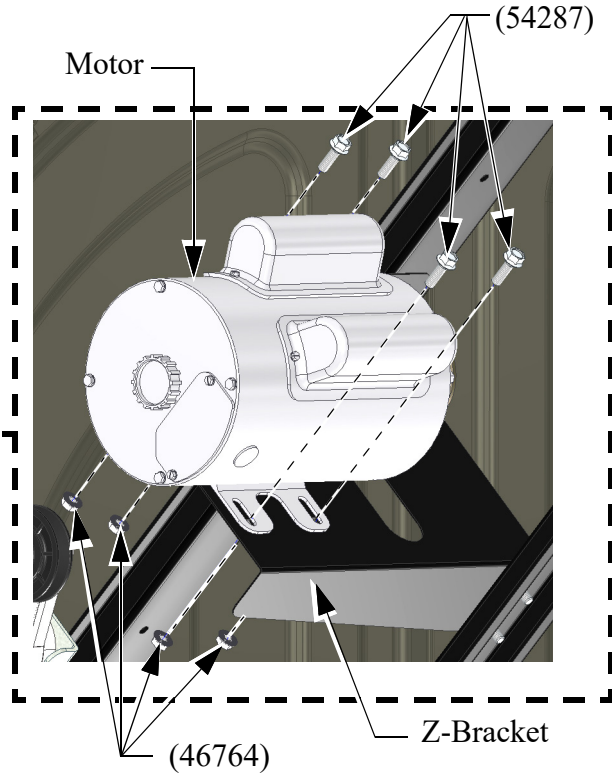
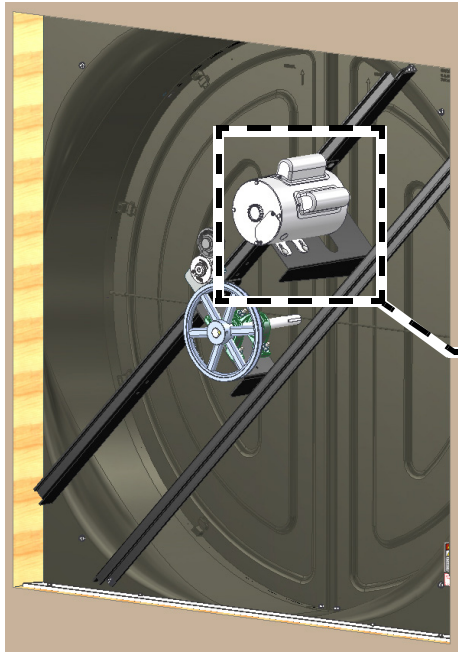

Torque Set Screw to 150-165 IN-LBS  
[16.9-18.6 NM]

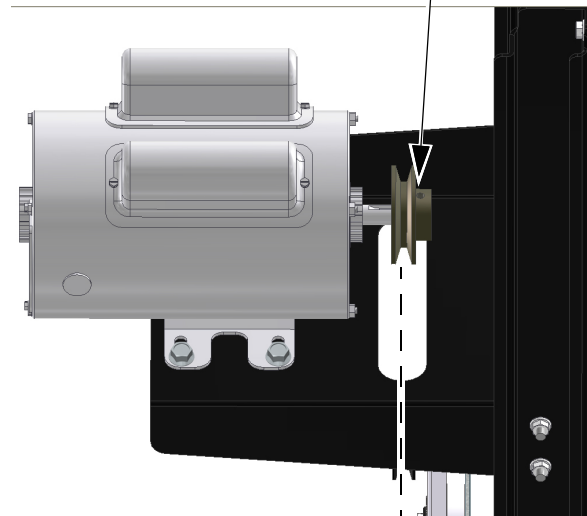
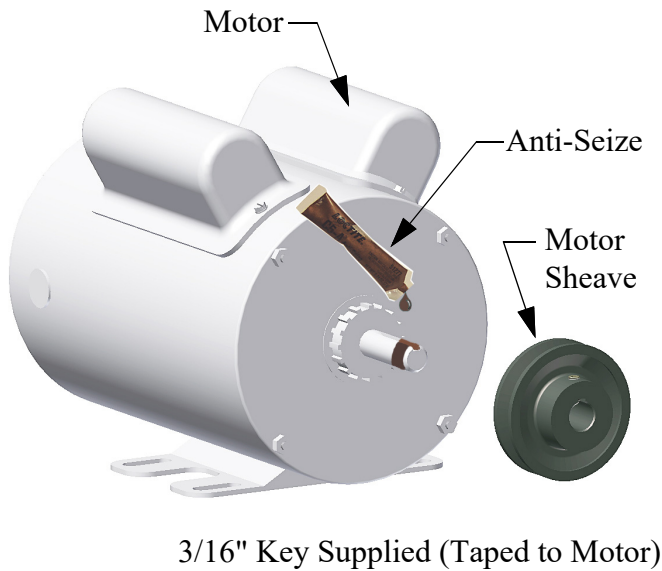

Center the Sheave with the  
Hole in the Z-Bracket

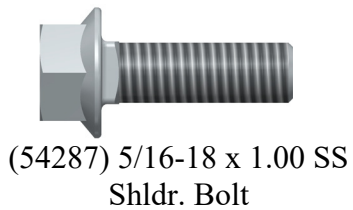

### Belt Installation

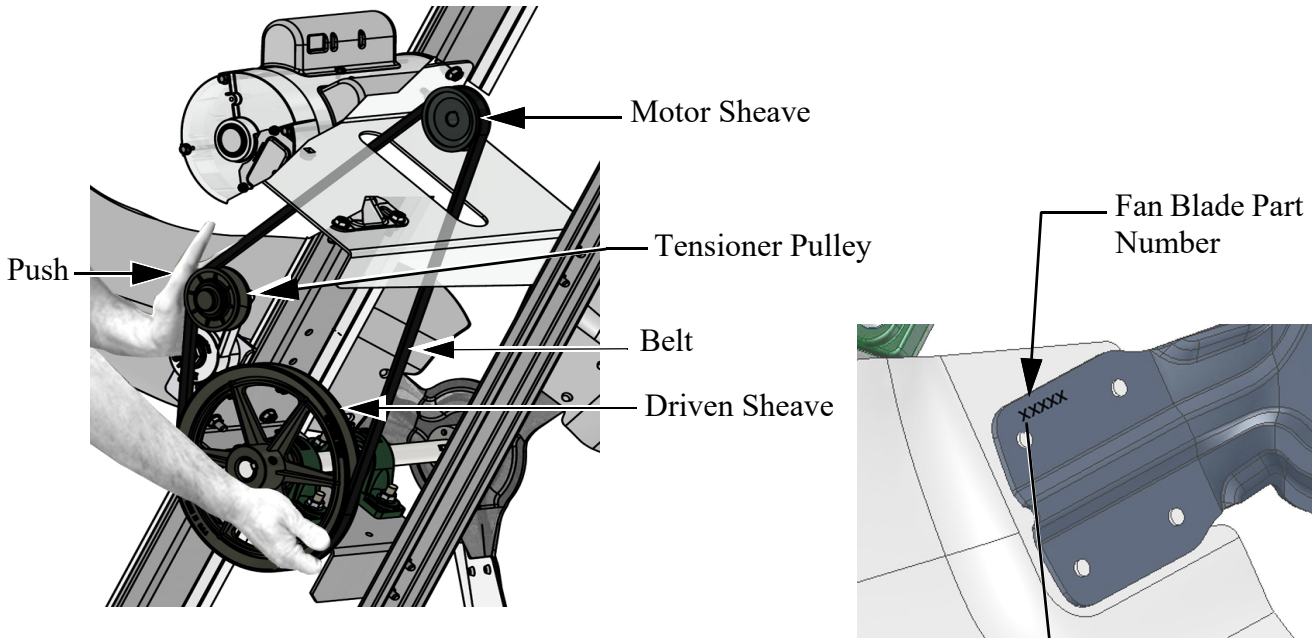

### Blade Installation

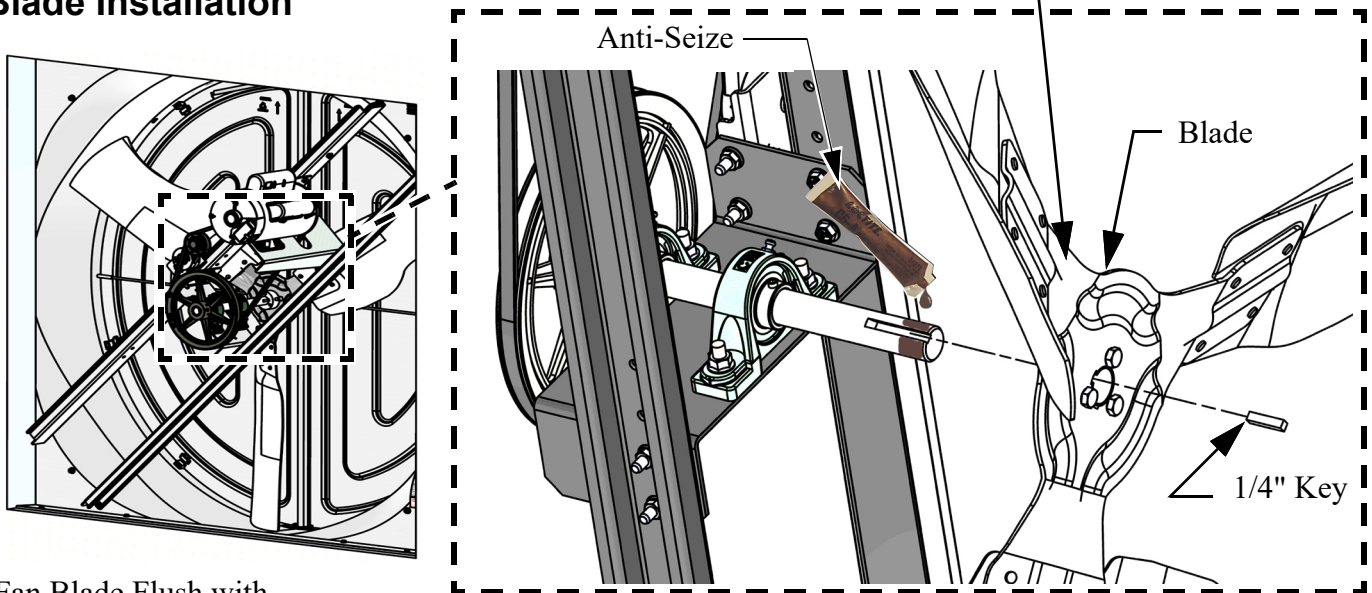

Fan Blade Flush with the End of Shaft.

Torque Blade Set Screw to 252 ± 8 IN LB [28.5 ± .9 Nm]

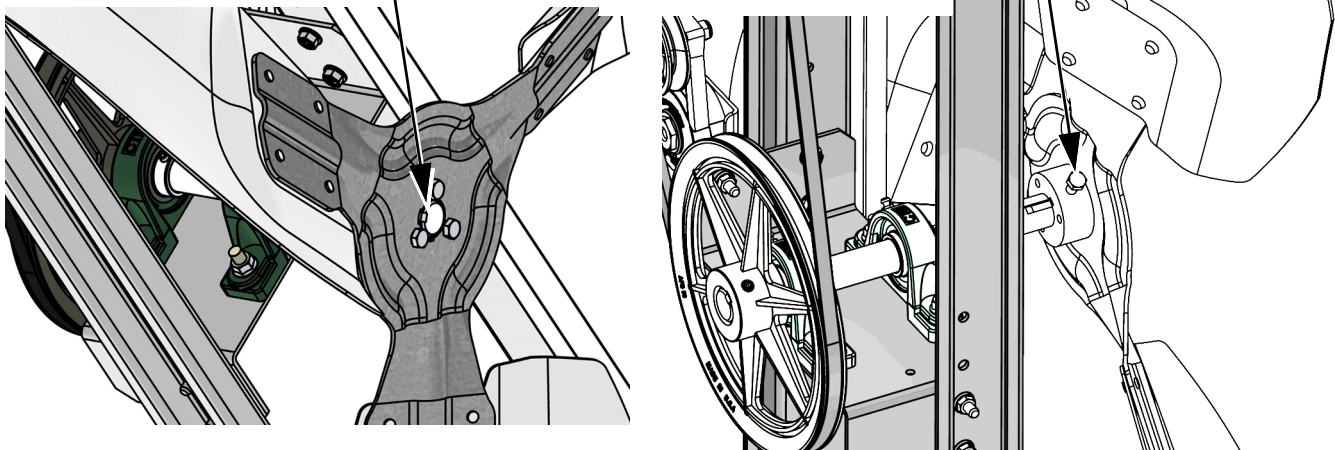

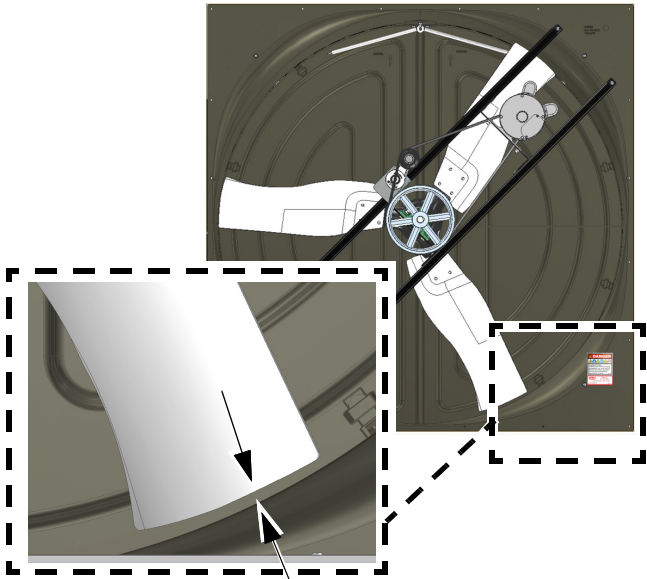

1/8" [3mm] Minimum

Spin the Blade by hand and check that there is minimum of 1/8" [3 mm] Clearance from the Shroud all the way around orifice.

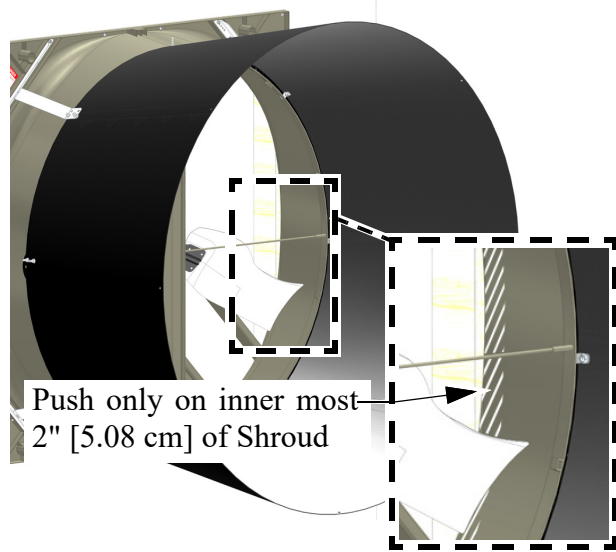

Push only on inner most 2" [5.08 cm] of Shroud

If Clearance is insufficient, check that the mounting surface is flat, and that the sides of the Shroud are straight. To Gain more Tip Clearance, remove the Lag Screws from the side with inadequate clearance, push out on the Shroud orifice. **(Push only on the inner most 2" [5.08 cm] of the Shroud or damage could occur)** Re-install Lag Screws in new holes.

### Door Spring Installation

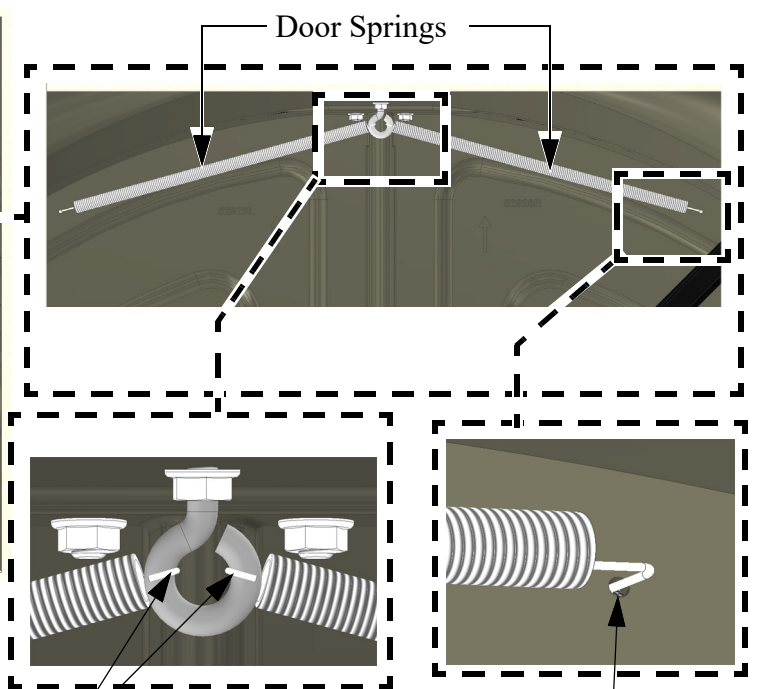
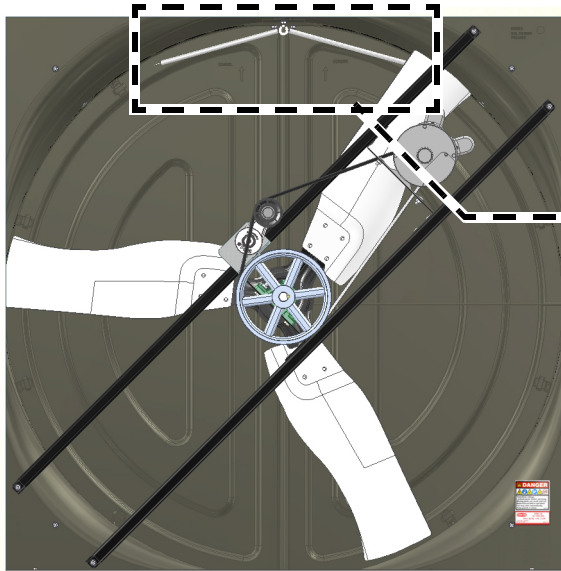

Rounded end of Springs attached to Eyehook

Elongated end of Spring attached to Door Hole



## Caulking

Caulk both Ends of the Bottom Shelf and as needed to fill any gaps between the Shroud and the Framed opening.

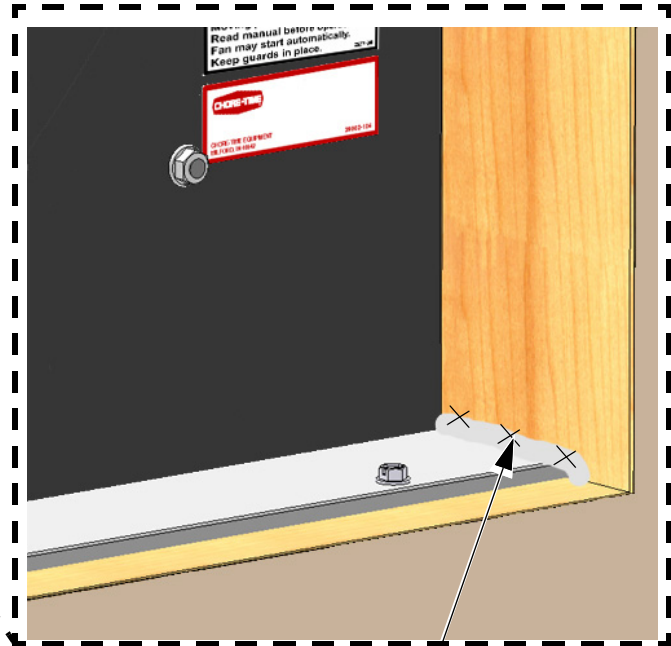
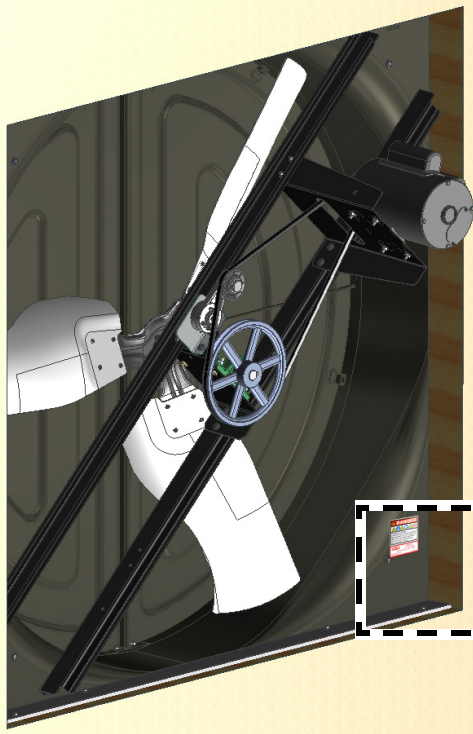

Caulk Both Ends of the Bottom Shelf

## Motor Wiring

1. Check that the electrical power being supplied to the Fan matches the electrical Specifications on the Fan and Motor Decals.
2. Remove the Motor Access Cover.
3. Install an electrical disconnect within reach of each Fan installed.
4. Connect the cord to the motor according to the wiring diagram on the motor. Verify that the motor is connected for counter clockwise rotation (viewing the back of the motor, opposite the shaft end.)
5. Follow local, state, and national electrical codes for wiring.
6. Attach the Cord to the Wall using a Screwhook **as shown**. Allow enough slack in the cord to form a "drip loop" for moisture to fall away from the cord and not into the motor.

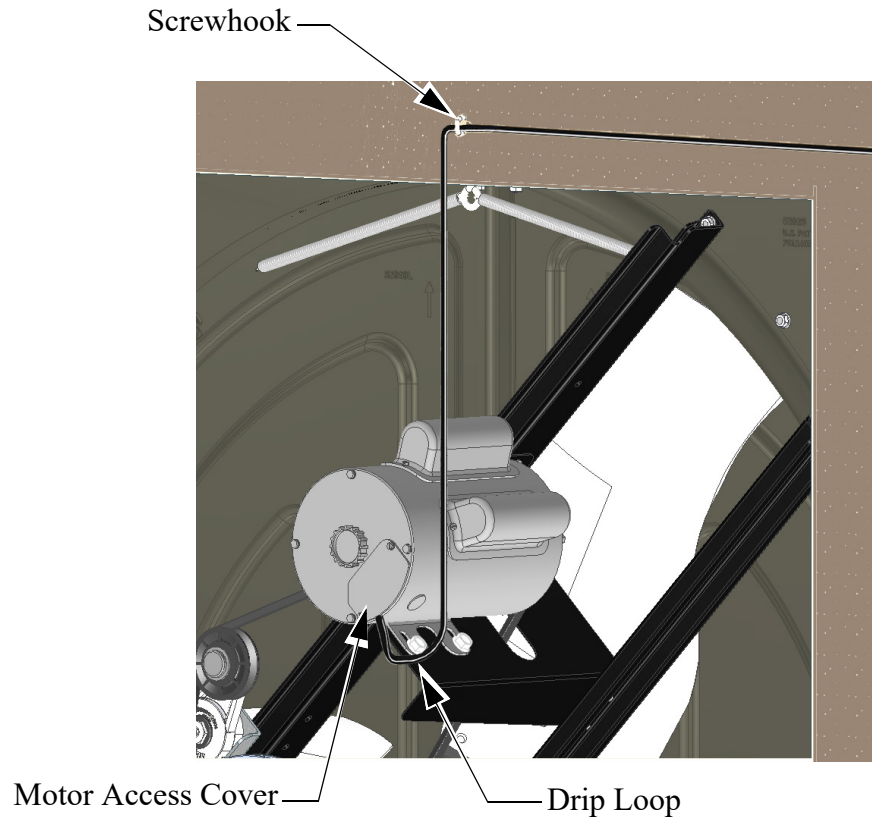

# Screen Assembly

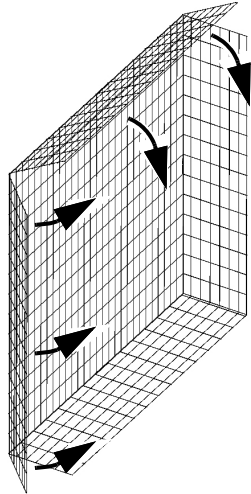

. Fold the Screen Sides as shown.

Install Spring per steps A-D below.

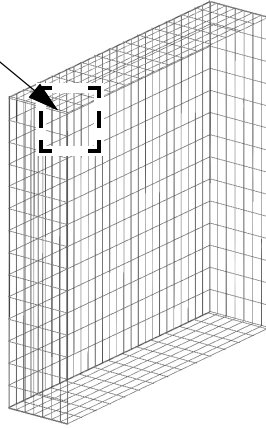

2. Install a spring (54480) in the **upper left corner** following steps A through D below. After Step D is complete go to step 3.

Install a Spring at each corner.

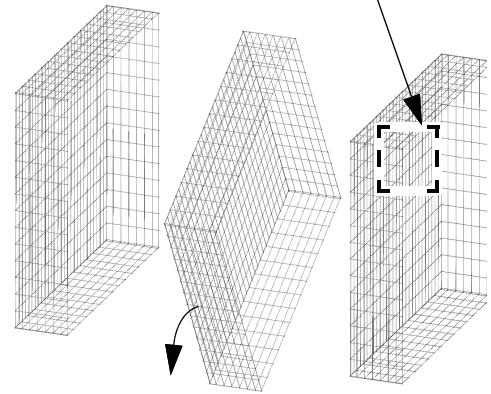

3. Rotate the Screen in the direction shown installing a Spring at a second corner. **Repeat for remaining Corners**

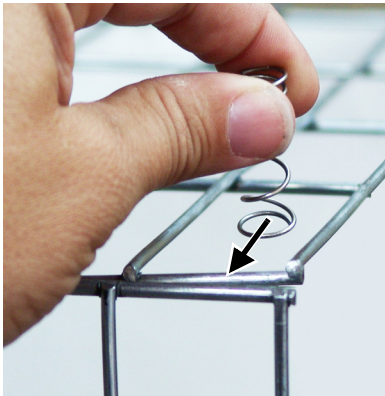

A) Slide a Spring (54480) over both Screen Panel Wires exactly as shown.

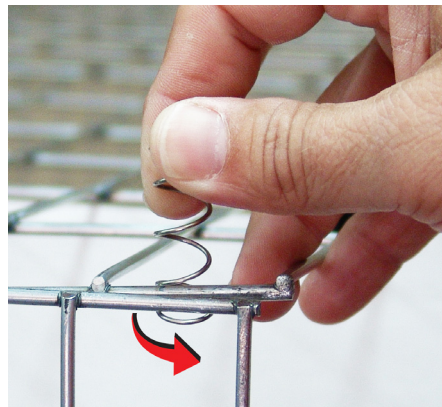

B) Rotate the Spring Counter-Clockwise until the end of the Spring snaps over the Side Panel Wire.

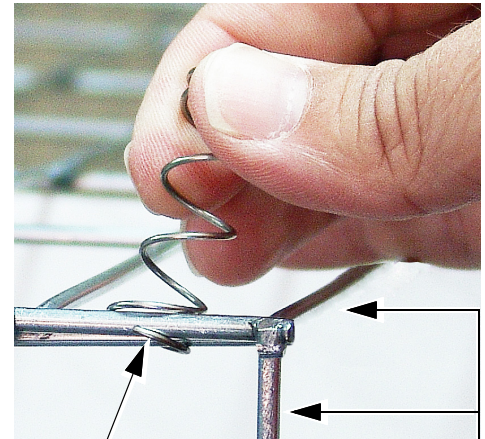

Adjust Screen Panels so they are as even as possible  
Snapped over Side Panel Wire

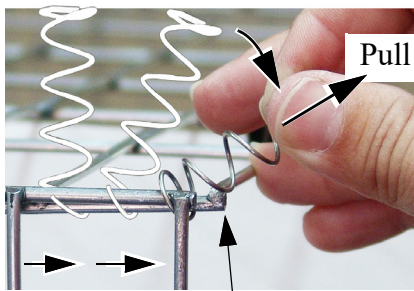

C) Slide and Pull Spring over Corner Panel Wire.

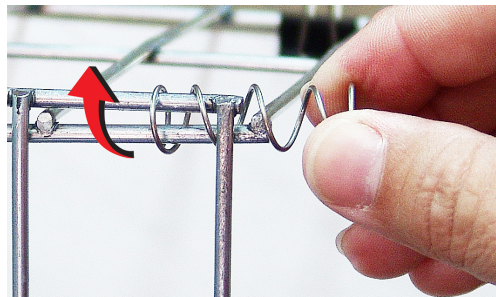

D) Twist Spring Clockwise until it is passed the outside wire and snapped firmly in place.

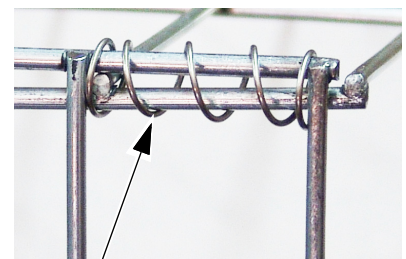

Spring snapped firmly between wires.

# Screen Installation

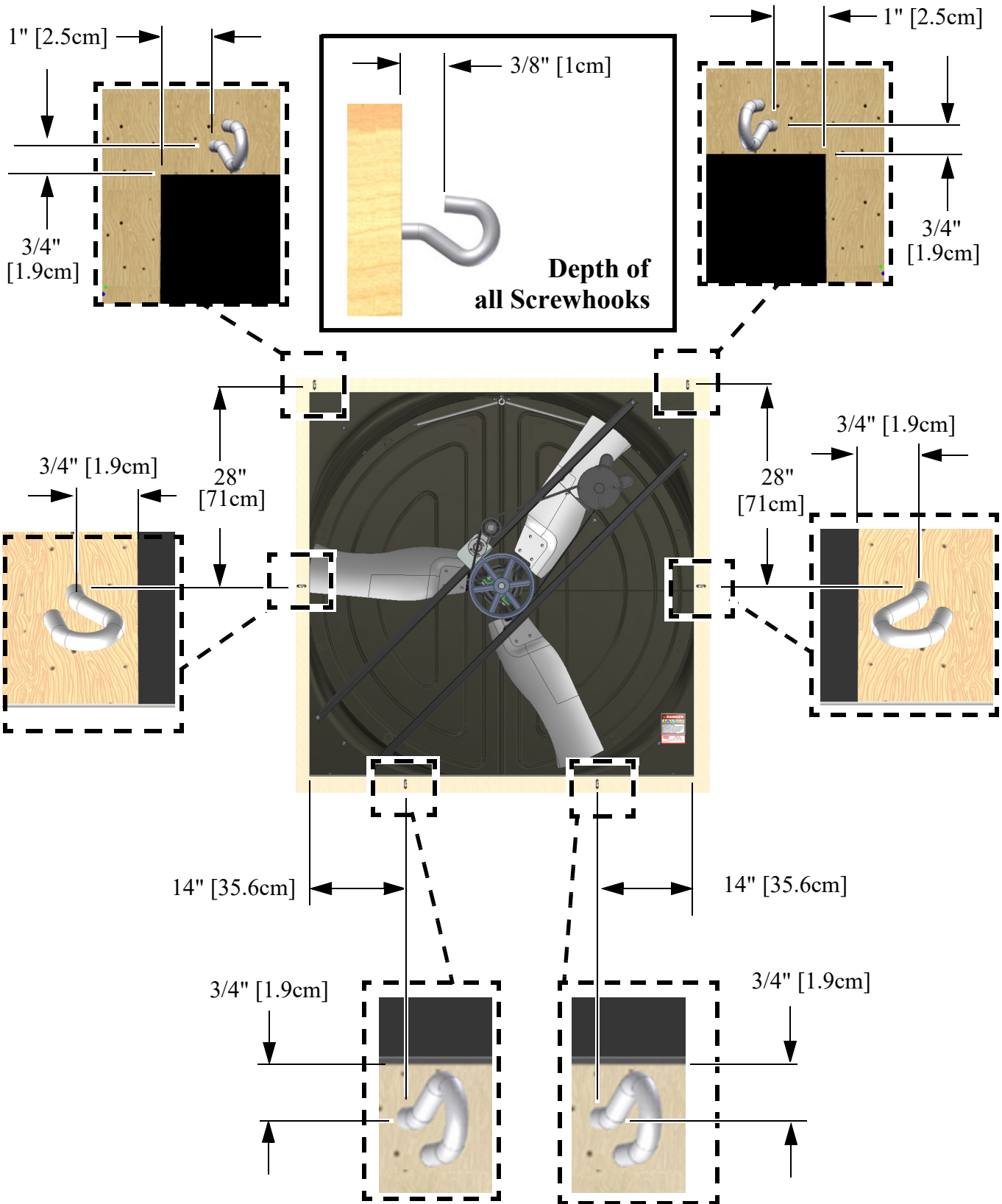

Continued on next page.....

# Screen Installation Continued

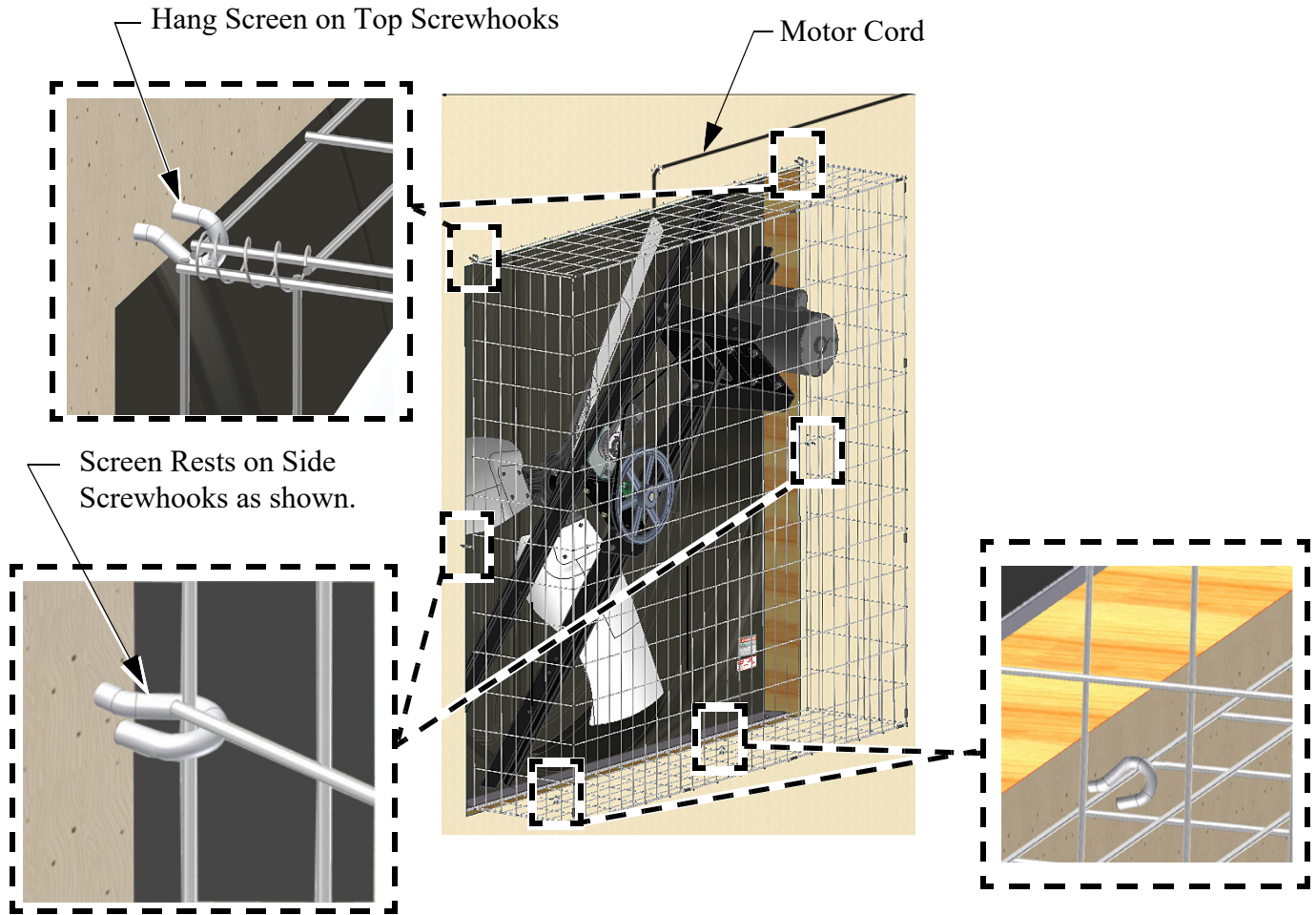

# Test Fan for proper operation.

Plug the Fan in and test for proper operation

## Maintenance

**IMPORTANT!** Disconnect Power Prior To Maintaining Or Cleaning The Fan. The fan may start automatically causing serious injury or death.

- Service and repair of fans should be done only by a qualified technician.
- Minimize contact of moisture or corrosive chemicals to the surfaces of the fan components to maximize fan life.
- After washing fans, operate fans long enough to remove moisture from all fan surfaces.
- Keep the fan clean for maximum life and best performance. **Do Not spray water on the Fan Shaft Bearings, the Belt Tensioner, or the Motor.**
- Periodically check the V-Belt and replace if necessary. A worn Belt will cause a substantial drop in Fan performance or it can break and cause Fan failure. If a Belt rides below the Sheave edge, replace the belt. (See below)

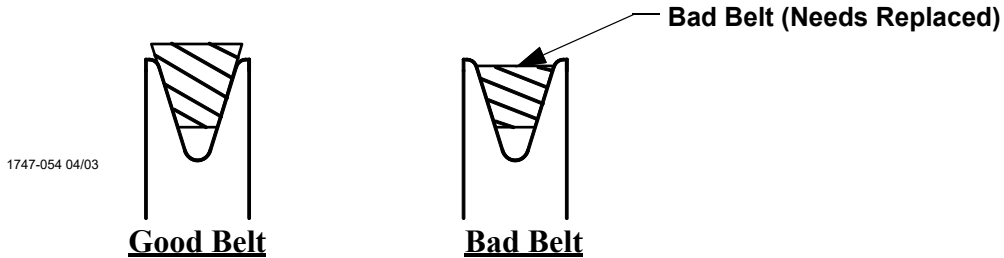

- Check Belt Tension. The Belt should be tensioned just tight enough to minimize Belt slippage. Over tensioning the belt will cause premature Belt and Bearing wear.
- The Alignment Mark on the Tensioner Base should be lined up with the 1st line on the Idler Support Bracket.

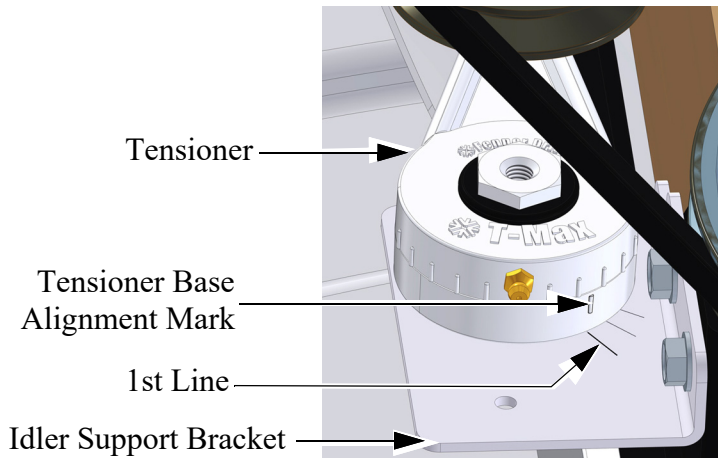

- Check Sheaves for wear. Replace if a Sheave groove is worn.

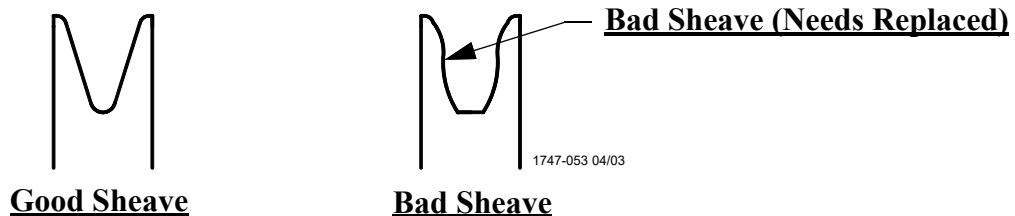

## Fan Bearing and Belt Tensioner Lubrication

- Grease zerks are provided for lubrication on the fan shaft bearings and the belt tensioner.
- Lubricate the fan every 2-6 months or whenever these components get wet.
- Disconnect power to the fan before lubricating.
- Clean the zerk before lubricating to prevent contamination from entering the bearing.
- Use a high quality lithium based, NLGI #2, grease such as Shell Gadus S2 V100 2. Do not use incompatible greases containing aluminum, barium, calcium, bentonite clay or polyurea thickeners.
- Slowly rotate the fan shaft by hand while slowly applying the grease. Rapidly applying grease to a stationary bearing can damage the bearing seals.
- Apply about .10 oz (2.8 g, 3.1 cc) of grease at a time or until a slight amount of grease can be seen purging from the seal.

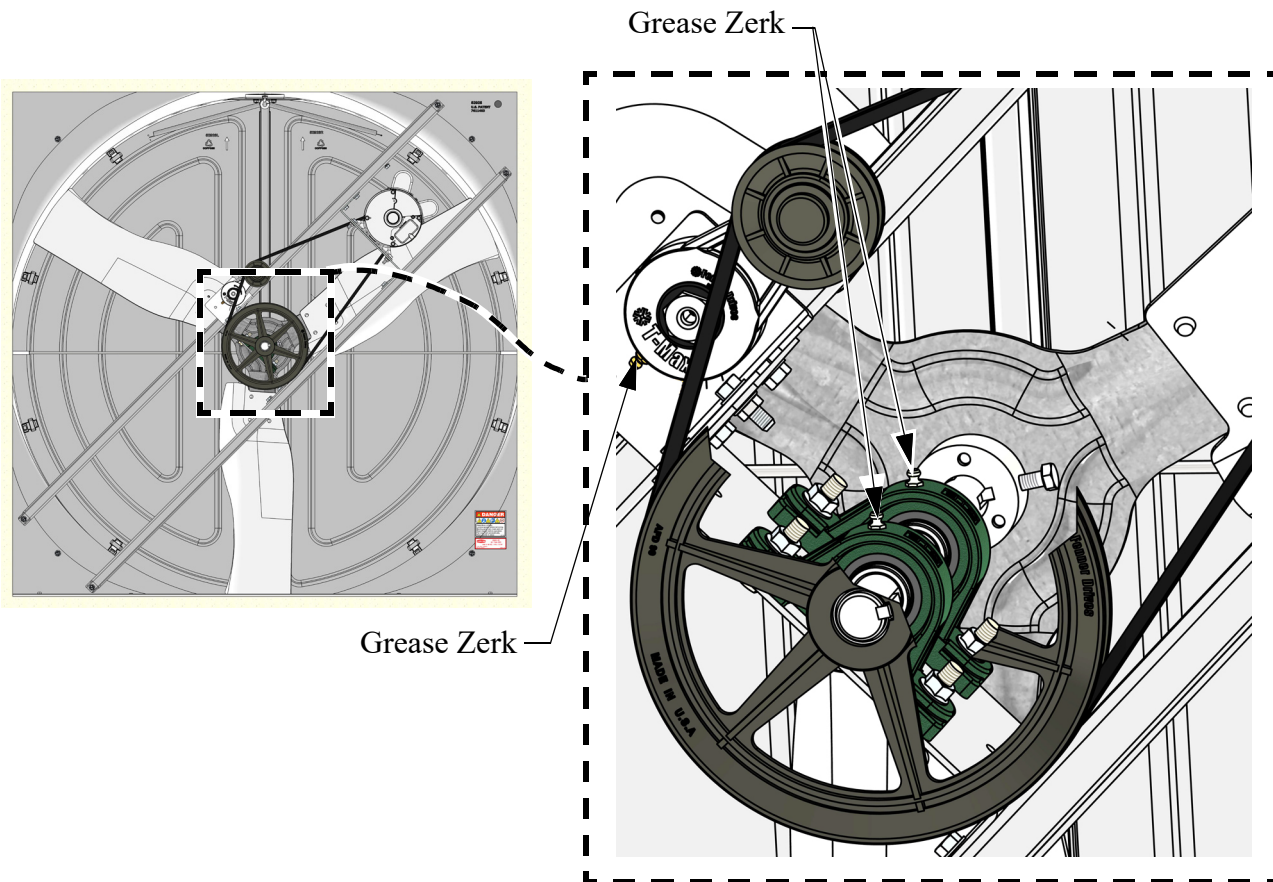

# Part Numbers (Itemized)

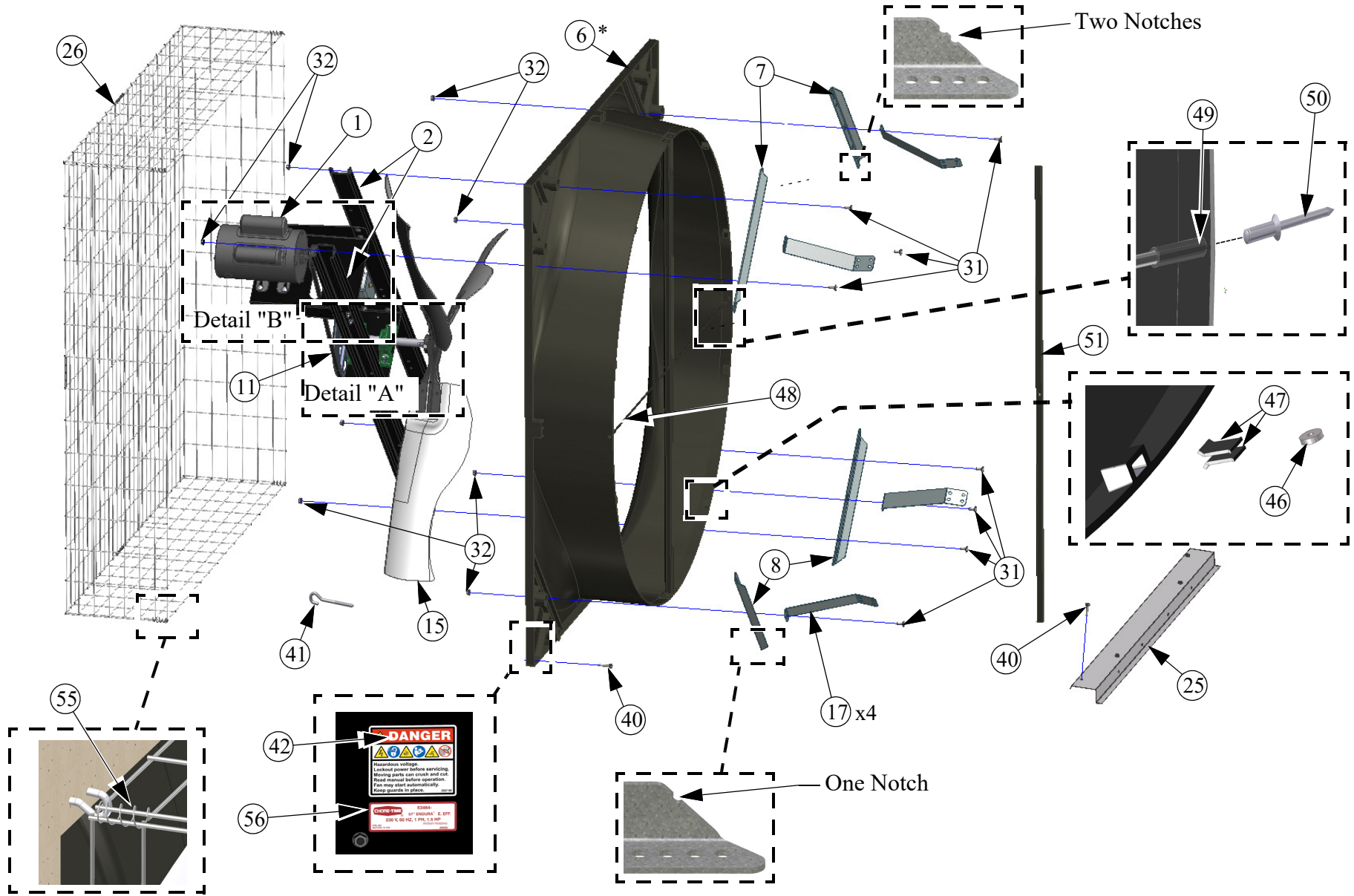



# Part Numbers

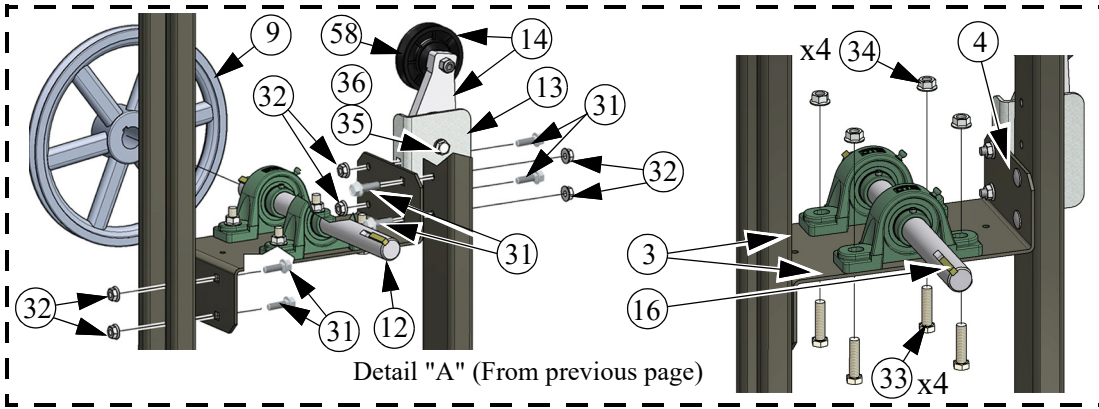

Detail "A" (From previous page)

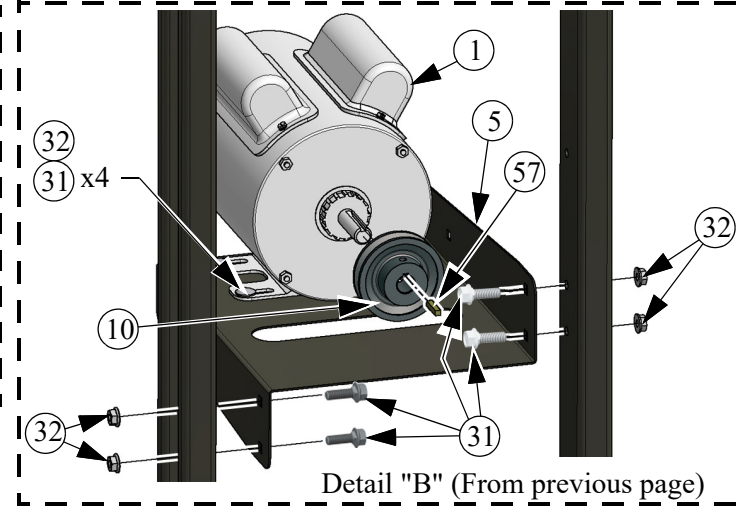

Detail "B" (From previous page)

## 57" Belt Drive Endura® Fan Part Numbers 53464-XX, -XXS

Item	Qty.	Description	Part No.	Models
1	1	Motor, 1.5H 1PH-60HZ-230V	56850	-22, -22S, -23
		Motor, 1.5H, 1.67SF 3PH-60HZ, 230/460V, 1.3SF 3PH-50/60HZ, 200-230/380-480V	56102	-41, -42, -45, -51, -52, -41S, -42S, -51S, -52S
		Motor, 1.5H 1PH-60HZ-230V	56708	-21, -21S
2	2	57" Fan Post	53204	All
3	2	1" Pillow Block Bearing	50553	All
4	1	Idler Drive Bearing Support	48395C	All
5	1	Idler Drive Motor Support	48396C	All
*6	1	57" Fan Shroud Assembly	52925	All
7	2	Upper Corner Support (2 Notches)	53205	All
8	2	Lower Corner Support (1 Notch)	53206	All
9	1	AFD99100 Composite Sheave	54118	-21, -22, -23, -41, -42, -21S, -22S, -41S, -42S
		AFD94100 x 1.00" Bore Composite Driven Sheave	54897	-51, -52, -51S, -52S
		AK89 x 1.00" Bore Sheave	57158	-45
10	1	AK30 3" O.D. x 5/8 Bore Motor Sheave	8773	-21, -22, -23, -41, -42, -45
		AK34	37919	-51, -52
11	1	AX60 V-Belt	48541	-21, -22, -23, -41, -42, -21S, -22S, -41S, -42S
	1	AX59 V-Belt	48615	-45
12	1	1" x 11.97" Fan Shaft	52083	-21, -22, -23, -41, -42, -45, -51, -52
		1" x 11.97 SS Fan Shaft	54438	-21S, -22S, -41S, -42S, -51S, -52S
13	1	Tensioner Support	49737	All
14	1	Tensioner Assembly 3.5" Arm 3" Dia.	48429	All
15	1	57" Galv. High Capacity Fan Blade	53219	-21, -41, -51, -45
		57" Galv. E. Efficiency Fan Blade	56494	-22, -42, -52
		57" High Capacity SS Fan Blade	54529	-21S, -41S, -51S
		57" E. Efficiency SS Fan Blade	57022	-22S, -42S, -52S
		57" Galv. Min. Vent Fan Blade	56108	-23

Item	Qty.	Description	Part No.	Models
16	2	1/4" Sq. 1.13" Key	2419-2	All
17	4	Cone Bracket	53039	All
25	1	57" Fan Support Shelf	53338	All
26	1	56 x 56 x 12.35 Inlet Screen	48794	All
31	41	5/16-18 x 1 SS Shoulder Bolt	54287	All
32	56	5/16-18 Hx. Serrated SS Flange Nut	46764	All
33	4	3/8-16 x 1.50 SS HH Bolt	4413-10	All
34	4	3/8-16 SS Serrated Flange Nut	50191	All
35	1	3/8-16 x .75 SS Hx. Bolt	ST99277	All
36	1	3/8 SS Lock Washer	ST99780	All
40	24	1/4-10 x 1-1/2 Lag Screw SS	41561	All
41	9	Open Eye Hook	1214	All
42	1	Fan Decal	39002-XXX	All
46	4	.125 x .50 Magnet	48427	All
47	8	Magnet Side Plate	53026	All
*48	1	57" Fan Cross Rod	53398	All
*49	2	57" Fan Cross Rod Coupler (Rivet)	56339	All
50	2	1/8 x .40 Countersunk SS Pop Rivet	48936	All
*51	1	57" Center V-Post	53626	All
55	1	Screen Spring (Package of 4)	54480-4	All
*56	2	Fan Danger Decal	2527-90	All
57	1	3/16 x 1-3/8 Key (w/motor)	--	All
58	-	Idler Pulley (Repair Part)	50879	All

\* Fan Shroud Assembly (Item 6) Includes items 48,49,50,51, and 56



## Part Numbers (Continued)

<b>57" Belt Drive Endura® Fan Part Numbers 53464-XX, or 53464-XX,XXS</b>				
<b>Item</b>	<b>Qty.</b>	<b>Description</b>	<b>Part No.</b>	<b>Models</b>
18	1	Orifice Frame	53416	All
19	6	Orifice Frame Bracket	53611	All
20	4	57" Cone Panel	53163	All
21	1	Top Pivot Plate	53037	All
22	1	Bottom Pivot Plate	53036	All
23	1	Ø1/2" x 11" Door Spring	49629	All
24	1	72" Fan Cone Cable	50618-5	All
27**	1	Left 57" Door Assembly	52926L	All
28**	1	Right 57" Door Assembly	52926R	All
29	4	1/4 x 1-3/4 420 SS Spring Pin	53038	All
30	1	70" Cone Grill	53129	All
31	42	5/16-18 x 1 HXWH SS Shoulder Bolt	54287	All
32	57	5/16-18 Hx. Serrated Flange Nut	46764	All
39	1	5/16-18 x 2 SS Eye Bolt	30663	All
52	4	Striker Plate	53027	All
53	2	Cable Clamp	732	All
54	1/3	Anti-Seize (Not Shown)	47749	All
<b>**Doors Include 53027 Striker Plates (Item 52)</b>				



**Made to work.  
Built to last.®**

### **Revisions to this Manual**

<b>Page No.</b>	<b>Description of Change</b>	<b>ECO</b>
5	Changed 53532-XX to 56494-X, 54530-XX to 57022	40133
6	Changed Grill Pictorial	
7,13,35	Changed 53399 to 50618-5	
23	Changed 5 Pictorials to show new Blade Style.	
31	Changed Pictorials to show new Blade Style	
33	Changed 53532-XX to 56494-X, 54530-XX to 57022-XX	
7, 20, 33, 34, 35	Removed: ST99070 Washers, One 46764 Flange Nut. Changed Cable Routing	

**For additional parts and information, contact your nearest Chore-Time distributor or representative.**

**Find your nearest distributor at: [www.choretime.com/contacts](http://www.choretime.com/contacts)**

CTB, Inc.  
PO Box 2000  
Milford, Indiana 46542-2000 USA  
Phone (574) 658-4101 Fax (877) 730-8825  
Email: [choretime@choretime.com](mailto:choretime@choretime.com)  
Internet: [www.choretime.com](http://www.choretime.com)